



Diamant- und Bornitrid-Schleifscheiben zum Schleifen von Werkzeugen



Diamond and boron nitride grinding wheels for tool and cutter grinding
Meules diamant et nitrure de bore pour l'affûtage d'outil





Anfahrtsbeschreibung

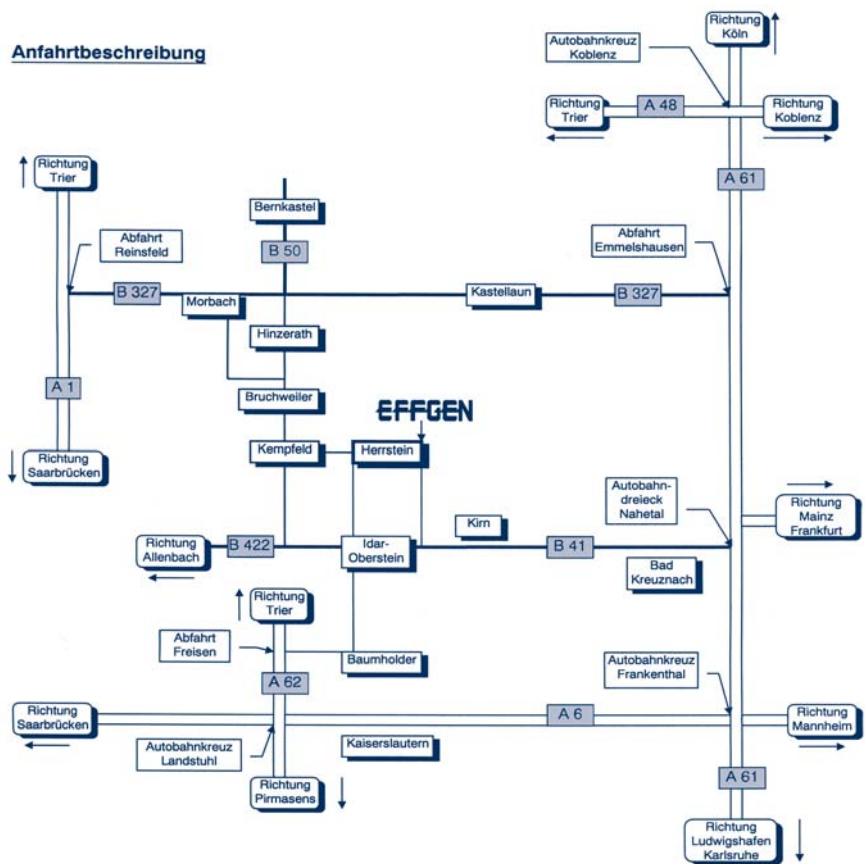

Inhaltverzeichnis
Table of contents
Sommaire

Technische Einführung

Technical introduction

Introduction technique

Auswahl der Bindungen

Application guide for bonds

Choix des liants2

Konzentrationen

Concentrations

Concentrations4

Körnungsgrößen

Grit sizes

Granulation5

Einsatzempfehlungen für verschiedene Schleifverfahren

Recommendations for different grinding operations

Instructions générales pour diverses opérations de rectification6

Diamant- und Bornitrid-Schleifscheiben zum Flachsleifen und Außenrundsleifen

Diamond- and boron nitride grinding wheels for surface and OD grinding

Meules diamant et nitrure de bore pour rectification de surface planes

et de surface extérieures cylindriques.....10

Diamant- und Bornitrid-Schleifscheiben zum Schleifen von Werkzeugen

Diamond- and boron nitride grinding wheels for tool and cutter grinding

Meules diamant et nitrure de bore pour l'affûtage d'outils11

Diamant- und Bornitrid-Schleifscheiben zum Schleifen von Kreissägen

Diamond- and boron nitride grinding wheels for saw sharpening

Meules diamant et nitrure de bore pour l'affûtage de scies15

Lieferprogramm

Product range

Programme de livraison.....37

Richtlinien für die Auswahl von Kunststoffbindungen / Application guide for resin bonds / Champs d'application pour le choix des liants résinoides

Kunststoffbindungen: Schleifscheiben in Kunststoffbindungen sind sehr schleiffreudig und zeichnen sich durch kühlen, werkstück-schonenden Schliff bei hoher Abtragsleistung aus. Sie werden

bevorzugt zum Schleifen von Hartmetall, hochlegierten Stählen und sonstigen metallischen Werkstoffen eingesetzt.

Resin bonds: Resin bond grinding wheels give very good removal rates, are particularly free cutting and cause only very little workpie-

ce damage even at high removal rates. They are normally used for grinding TC, high alloy steels and other metals.

Liants résinoides: Les meules à liants résinoides ont de très bonnes propriétés abrasives ainsi qu'un bon refroidissement naturel qui assure un taux d'enlèvement de métal important avec un bon

état de surface. Elles sont utilisées de préférence lors de la rectification de métal dur, d'acier fortement alliés ainsi que d'autres matériaux métalliques.

Diamant-Schleifscheiben / diamond grinding wheels / meules diamant		Lackierung Coat of paint Couleur	Bindungshärte / Bond hardness / Dureté du liant			
			J	N	R	T
K 200	Hochleistungsschleifen, trocken High efficiency grinding, dry Rectification à haut rendement, à sec	gelb yellow jaune	○	○	○	○
K 400	Hochleistungsschleifen, naß High efficiency grinding, wet Rectification à haut rendement, sous arrosage	blau blue bleu	○	○	○	○
K 600	Naßschleifen von Hartmetall/Stahlkombinationen Wet grinding TC/steel combination Rectification sous arrosage de métal dur / combinaisons d'acier	blau blue bleu	○	○	○	○
K 800	Sonderbedingungen für spezielle Anwendungen Special bonds for special applications Liants utilisés dans des cas spéciaux	blau blue bleu	○	○	○	○
Bornitrid-Schleifscheiben / boron nitride grinding wheels / meules nitrure de bore						
K 300	Hochleistungsschleifen, trocken High efficiency grinding, dry Rectification à haut rendement, à sec	grün green vert	○	○	○	○
K 500	Hochleistungsschleifen, naß High efficiency grinding, wet Rectification à haut rendement, sous arrosage	rot red rouge	○	○	○	○
K 700	Sonderbedingungen für spezielle Anwendungen Special bonds for special applications Liants utilisés dans des cas spéciaux	rot red rouge	○	○	○	○

Die erste Ziffer kennzeichnet den Anwendungsfall, die beiden letzten Ziffern sind spezielle Modifizierungen.

Bindungshärten:

J = weich: für Topf- und Tellerscheiben, Umfangscheiben, große Schleifrandbreite

N = mittel: für Topf- und Tellerscheiben, Umfangscheiben, mittlere Schleifrandbreite

R = hart: für Topfscheiben mit kleiner Schleifrandbreite, sehr verschleiß- und kantenfest

T = sehr hart: für spezielle Zwecke

Trägerkörper:

Für kunststoffgebundene Schleifscheiben stehen unterschiedliche Trägerkörper zur Verfügung. Sie unterscheiden sich in der mechanischen Festigkeit, der Wärmeleitfähigkeit und der Schwingungs-

dämpfung. Das Kennzeichen für das Trägerkörpermaterial wird an die Bindungsbezeichnung angehängt.

Folgende Trägerkörper stehen zur Wahl:

Trägermaterial	Kennzeichen
Aluminium/Kunststoff	ohne, da Standard
Aluminium	A z.B. K 200 NA
Formpreßmasse	B z.B. K 500 JB
Stahl	E z.B. K 400 RE

Die Auswahl des Trägermaterials der EFFGEN-Diamant- und Bornitrid-Schleifscheiben erfolgt nach Einsatz- und Verwendungszweck durch den Hersteller.

The first digit characteristics the grinding operation, the last two digits are specific modifications.

Bond hardness:

J = soft: for straight and flared cup wheels, peripheral wheels of large rim width

N = medium: for cup and flared cup wheels, peripheral wheels of medium rim width

R = hard: for cup wheels with narrow rim width

T = very hard: for special applications

Base material:

For resin bond grinding wheels different base materials are available. They differentiate in regard of mechanical strength, thermal conductivity and vibrations damping.

The characteristic sign of the base material is shown at the end of the bonding name:

Following base materials are available:

base material	sign in bonding name
aluminium/resin	no sign, standard
aluminium	A ex. K 200 NA
moulding press material	B ex. K 500 JB
steel	E ex. K 400 RE

The selection of the base materials of EFFGEN diamond and boron nitride grinding wheels happens, according to the range of application, by the manufacturer.

Le premier chiffre indique le champ d'application, les deux autres sont des modifications propres.

Valeurs de dureté du liant:

J = doux: pour meules à boisseau, à cuvette ou périphériques à grande surface abrasive

N = moyen: pour meules à boisseau, à cuvette ou périphériques à surface abrasive moyenne

R = dur: pour meules à boisseau à petite surface abrasive, avec une bonne résistance à l'usure et une bonne stabilité des arêtes

T = très dur: pour cas spéciaux

Corps de support: Il existe de nombreuses matières de support pour les meules à liant résinoïdes. Ils se différencient par leur rigidité

mécanique, l'évacuation de la chaleur et l'amortissement des vibrations. Le repère du support sera associé à la désignation du liant.

Les supports suivants sont disponibles:

Support	repère
aluminium/résinoïde	aucun car standard
aluminium	A p.e. K 200 NA
masse de forme coulée	B p.e. K 500 JB
acier	E p.e. K 400 RE

Pour les meules diamant et niture de bore, le choix du support sera fait par le fabricant en fonction des critères d'application.

Richtlinien für die Auswahl von Metallbindungen / Application guide for metal bonds / Champs d'application pour le choix des liants métalliques

Metallbindungen: Diamant- und Bornitrid-Schleifscheiben in Metallbindung sind bedingt durch die größere mechanische Festigkeit der Bindung und durch die Verarbeitung von blockigen, bruchfesteren Körnungstypen wesentlich verschleißfester und stoßunempfindlicher als Schleifscheiben in Kunststoffbindung. Sie erreichen durch die größere Bindungshärte nicht das hohe Zeitspanvolumen einer kunststoffgebundenen Schleifscheibe. Metallgebundene

ne Diamant-Schleifscheiben werden bevorzugt zum Schleifen von nichtmetallischen Werkstoffen wie keramischen Materialien, Glas usw. eingesetzt. Durch die Vielzahl der Anwendungsmöglichkeiten behält sich der Hersteller die Auswahl der optimalsten Bindung vor. Wir sind stets bemüht, unseren Kunden die neueste Entwicklung an Bindungen zu liefern. Es können dadurch Änderungen innerhalb der dreistelligen Bindungsnummer auftreten.

Metal bonds: Metal bond diamond and boron nitride grinding wheels, because of higher mechanical strength of the bond material itself and of the tougher, blocky grit types normally used for these bond systems, are considerable more wear resistant and less sensible to impact forces than resin bond tools. They do, however, not allow for the high removal rates like their resin bond counterparts. Metal bond diamond grinding wheels therefore are preferred for

machining non-metallic materials such as ceramics, glass, etc. Because of the great variety of applications the manufacturer reserves the right to choose the optimum bond specification. It is our honest endeavour to supply our customer with the latest in bond development and it may therefore happen that the bond type designation number is changed.

Liants métalliques: Les meules diamant et niture de bore à liant métallique sont beaucoup plus résitantes à l'usure et moins sensibles aux chocs que les meules à liant résinoïde, étant donné la plus grande solidité mécanique du liant et l'utilisation de types de grains plus gros et plus résistants à la fracture. Du fait de leur plus grande dureté de liaison, ces meules n'atteignent pas la même efficacité d'enlèvement de matériau que les meules à liant résinoïde. Les meules diamant à liant métallique sont utilisées de préférence pour

la rectification de matériaux non-métalliques, par exemple des matériaux céramiques, du verre etc. Etant donné le nombre considérable de possibilités d'emploi, le fabricant se réserve le droit de choisir le liant optimum. Nous nous engageons à livrer à notre clientèle les types de liant les plus récents. Pour cette raison, il peut y avoir des changements dans le numéro du liant composé de trois chiffres.

Diamant-Schleifscheiben für die Hartmetallbearbeitung Diamond wheels for grinding TC Meules diamant appliquées aux métal dur	Bindungshärte / Bond hardness / Dureté du liant			
	J	N	R	T
M 100 für allgemeine Schleifaufgaben im Trockenschliff for general dry grinding applications pour des travaux de rectification généraux à sec	○	○	○	○
M 200 für allgemeine Schleifaufgaben im Naßschliff for general wet grinding applications pour des travaux de rectification généraux sous arrosage	○	○	○	○
Bornitrid-Schleifscheiben für hochlegierte Stähle Boron nitride wheels for grinding high alloy steels Meules niture de bore pour aciers fortement alliés				
M 600 für allgemeine Schleifaufgaben im Trockenschliff for general dry grinding applications pour des travaux de rectification généraux à sec	○	○	○	○
M 800 für allgemeine Schleifaufgaben im Naßschliff for general wet grindging applications pour des travaux de rectification généraux sous arrosage	○	○	○	○

Konzentration

Der volumenmäßige Anteil an Schleifmittel in dem Schleifbelag ergibt sich aus der Konzentrationsangabe. Bei Diamant sagt die Angabe C 100 aus, daß pro Kubikzentimeter Belagvolumen 4,4 Kt (1 Karat \pm 0,2 Gramm) Körnung verarbeitet werden. Dies ergibt sich unter Berücksichtigung der Dichte des Diamanten von 3,52 g/cm³ einen Volumenanteil von 25%.

Die C 100 besagt bei Bornitrid, daß je Kubikzentimeter Belagvolumen 4,18 Kt Körnung verarbeitet werden. Hieraus ergibt sich aufgrund der Dichte des Bornitrids ein Volumenanteil von 24%.

Gängige Konzentrationen sind:

Konzentration	Karat/Kubikzentimeter	
	Diamant	Bornitrid
C 25	1,1	1,05
C 50	2,2	2,09
C 75	3,3	3,13
C 100	4,4	4,18
C 125	5,5	5,22
C 150	6,6	6,27

Concentrations

The concentration gives information about the volume percent of grit which is used in the rim. The basis for defining concentrations is by diamond 4,4 ct/cm³ (1 carat \pm 0,2 gramme) rim volume by concentration C 100. This concentration value is equivalent to a diamond grit content of 25 volume percent of the total matrix volume with a density of 3,52 g/cm³ for diamond.

By boron nitride concentration C 100 means a content of 4,18 ct/cm³ rim volume. With a density for boron nitride the concentration value C 100 is equivalent to a boron nitride grit content of 24 volume percent of the rim volume.

Frequently used concentration values are:

concentration	carats/cubiccentimeter	
	diamond	boron nitride
C 25	1,1	1,05
C 50	2,2	2,09
C 75	3,3	3,13
C 100	4,4	4,18
C 125	5,5	5,22
C 150	6,6	6,27

Concentrations

La concentration nous indique la partie volumique d'abrasif contenue dans le bandau. Pour le diamant, une concentration de C 100 nous donne 4,4 carat/cm³ de couche abrasive (1 carat \pm 0,2 gramme). Cela correspond en considérant un poids spécifique de 3,52 g/cm³ pour le diamant, à 25 % volumique de la couche abrasive.

Pour le nitrure de bore une concentration de C 100 donne, 4,18 ct/cm³, ce qui correspond à 24 % volumique de la couche abrasive.

Les concentrations les plus usitées sont:

concentrations	carat/centimetre cube	
	diamant	nitrure de bore
C 25	1,1	1,05
C 50	2,2	2,09
C 75	3,3	3,13
C 100	4,4	4,18
C 125	5,5	5,22
C 150	6,6	6,27

Hohe Konzentrationen 75 – 150 werden bei groben Körnungen für Umfangscheiben, Profilscheiben bei kleiner Berührungsfläche oder geringer Schleifrandbreite eingesetzt.

Niedrigere Konzentrationen 25 – 50 bei feinen Körnungen, großer Belagbreite sowie für stirnseitiges Flachscheifen mit Topfscheiben.

Wir garantieren, daß in EFFGEN-Diamant- und Bornitrid-Schleifscheiben diesen Konzentrationswerten entsprechende Diamant- bzw. Bornitrid-Gewichte verarbeitet werden.

Körnungsgrößen

Es ist immer vorteilhaft, die größtmögliche noch in Bezug auf Oberflächengüte zulässige Körnungsgröße zu wählen, um ein optimales Zeitspanvolumen zu erreichen.

EFFGEN-Diamant- und Bornitrid-Körnungen werden nach dem FEPA-Standard bezeichnet. Hier wurde unter Berücksichtigung des neuesten Standes der Technik die bisher präziseste Prüfsiebvorschrift für Schleifkörnungen festgelegt.

High concentrations of 75 to 150 are typical for coarse grits in peripheral wheels, profile wheels of small contract area or small rim width.

Low concentration of 25 to 50 are used with fine grits for wheels of large rim width as well as for face grinding with cup wheels.

We guarantee that the diamond and boron nitride grit content of EFFGEN diamond and boron nitride grinding wheels correspond to these concentrations values.

Grit sizes

For optimum stock removal capability it is generally of advantage to use the largest grit size allowing surface quality requirements.

EFFGEN diamond and boron nitride grit size conform to the FEPA-Standard. This standard prescribes the most precise test sieve specifications for abrasive grits under consideration of the latest technological developments.

Les hautes concentrations de l'ordre de 75 à 150 sont utilisées pour les gros grains employés sur meules périphériques, les meules à profiler avec petite surface de contact ou dans le cas d'une surface abrasive étroite.

Les faibles concentrations de l'ordre de 25 à 50 sont utilisées pour les grains fins employés dans le cas d'une surface abrasive très large, ainsi que pour la rectification de la surface d'attaque de surfaces planes à l'aide d'une meule boisseau.

Nous garantissons que le contenu en diamant ou nitrure de bore des meules EFFGEN correspond à ces valeurs de concentration.

Granulation

Il est toujours avantageux de choisir la plus grande granulation possible sans qu'il y ait une diminution de la qualité de la surface et ce pour attendre un volume de coupe optimum.

Les granulations de diamant et de nitrure de bore sont définies suivant le standard FEPA. En tenant compte des développements les plus récents dans la domaine technique, ce standard contient les prescriptions granulométriques les plus précises relatives aux particules abrasives.

	Vorschliff / Pre-grinding / Rectification d'ébauche	Fertigschliff / Finish grinding / Finition
Diamant/Diamond/Diamant	D 181 (D 151)	D 126 (D 91)
Bornitrid/Boron nitride/Nitrure de bore	B 151	B 126
	Feinschliff / Fine grinding / Polissage	Läppschliff / Lapping / Rodage
Diamant/Diamond/Diamant	D 64 (D 46)	D 30 (D 15)
Bornitrid/Boron nitride/Nitrure de bore	B 91	B 46

Standard-Körnungsgrößen für Diamant und Bornitrid
Standard grit sizes for diamond and boron nitride
Grosseurs standard des grains de diamant et de nitrure de bore

Diamant Diamond Diamant		Bornitrid Boron nitride Nitrure de bore		US-Standard Standard US Standard US	Nennmaschenweite nach ISO R 565 – 72 Nominal ISO sieve aperture range ISO R 6109-80 (µm) Maillage nominal ISO R 565 – 72 (µm)
FEPA Standard eng narrow étroit	weit wide large	FEPA Standard eng narrow étroit	weit wide large	ASTM-E-11-70 (US Mesh) eng narrow étroit	
				weit wide large	
D 301		B 301		50/60	300-250
D 251	D 252	B 251	B 252	60/70	250-212
D 213		B 213		70/80	212-180
D 181		B 181		80/100	180-150
D 151		B 151		100/120	150-125
D 126		B 126		120/140	125-106
D 107		B 107		140/170	106-90
D 91		B 91		170/200	90-75
D 76		B 76		200/230	75-63
D 64		B 64		230/270	63-53
D 54		B 54		270/325	53-45
D 46		B 46		325/400	45-38
D 35				400/500	40-32
D 30		B 30		500/600	32-25
D 25					30-20
D 20					25-15
D 15		B 15			20-10

Einsatzempfehlungen für verschiedene Schleifverfahren

Recommendations for different grinding operations

Instructions générales pour diverses opérations de rectification

Flachschleifen / Surface grinding / Rectification de surfaces planes			
Pendelschleifen Oscillation grinding Rectification oscillante		Diamant Diamond Diamant	Bornitrid Boron nitride Nitrure de bore
Schnittgeschwindigkeit Schleifscheibe Wheel peripheral speed Vitesse de coupe de la meule	v_c m/s	20 – 25	25 – 35
Zustellung pro Überlauf Infeed per pass Profondeur de passe par course	a_e mm	≤ 20 %	Korngröße/ Grit size/ Granulation
Tischgeschwindigkeit Table speed Vitesse de table	v_{ft} m/min	6 – 16	8 – 20
Quervorschub Crossfeed Avance transversale	a_p mm	≈ 0,5x Scheibenbreite ≈ 0,5x Rim width ≈ 0,5x Largeur de la surface abrasive	
Kühlung Coolant Refroidissement		Emulsion oder Öl Emulsion or oil Emulsion ou huile	
Scheibenspezifikation Wheel specification Spécification de la meule			
Körnungsgröße Grit Size Granulation		D 91 – D 151	B 126 – B 181
Konzentration Concentration Concentration		75	50 (75)
Bindung Bond Liant		K400NB, K400JB	K506NB, K500JB
Tiefschleifen Deep grinding Rectification en plongée		Diamant Diamond Diamant	Bornitrid Boron nitride Nitrure de bore
Schnittgeschwindigkeit Schleifscheibe Wheel peripheral speed Vitesse de coupe de la meule	v_c m/s	22 – 30	25 – 40
Zustellung Infeed Profondeur de passe	a_e mm	0,2 – 3,0	0,2 – 5,0
Tischgeschwindigkeit Table speed Vitesse de table	v_{ft} mm/min	15 – 100	50 – 250
Kühlung Coolant Refroidissement		Vollsynthetische Lösung oder Öl Fully synthetic solution or oil Solution entièrement synthétique ou huile	
Scheibenspezifikation Wheel specification Spécification de la meule			
Körnungsgröße Grit size Granulation		D 54 – D 76	B 64 – B 91
Konzentration Concentration Concentration		100 (125)	100 (125)
Bindung Bond Liant		K833N, K850R	K850R

Einsatzempfehlungen für verschiedene Schleifverfahren
Recommendations for different grinding operations
Instructions générales pour diverses opérations de rectification

Außenrundscheifen / OD grinding / Rectification de surfaces extérieures cylindriques			
Pendelschleifen Oscillation grinding Rectification pendulaire		Diamant Diamond Diamant	Bornitrid Boron nitride Nitrure de bore
Schnittgeschwindigkeit Schleifscheibe Wheel peripheral speed Vitesse de coupe de la meule	v_c m/s	20 – 25	25 – 35
Werkstückgeschwindigkeit Work piece speed Vitesse de la pièce	v_w m/min	8 – 18	12 – 20
Werkstückvorschub pro Umdrehung Feed per revolution Avance de la pièce par tour	v_{fa} mm/min	$\approx 0,5x$ Scheibenbreite $\approx 0,5x$ Rim width $\times n_w$ $\approx 0,5x$ Largeur de la surface abrasive	
Zustellung Infeed Profondeur de passe	a_e mm	$\leq 20\%$ Körnungsgröße $\leq 20\%$ Grit size $\leq 20\%$ Granulation	
Kühlung Coolant Refroidissement		Emulsion oder Öl Emulsion or oil Emulsion ou huile	
Scheibenspezifikation Wheel specification Spécification de la meule			
Körnungsgröße Grit size Granulation		D 64 – D 151	B 91 – B 181
Konzentration Concentration Concentration		75	75
Bindung Bond Liant		K 400 NB	K 500 NB
Tiefschleifen CNC – UWS Deep grinding CNC – UWS Rectification en plongée CNC - UWS		Diamant Diamond Diamant	Bornitrid Boron nitride Nitrure de bore
Schnittgeschwindigkeit Schleifscheibe Wheel peripheral speed Vitesse de coupe de la meule	v_c m/s	22 – 30	25 – 40
Werkstückgeschwindigkeit Work piece speed Vitesse de la pièce	v_w m/min	5 – 20	5 – 20
Werkstückvorschubgeschwindigkeit Feed rate Vitesse de l'avance de la pièce	v_{fa} mm/min	1 – 20	1 – 20
Kühlung Coolant Refroidissement		Vollsynthetische Lösung oder Öl Fully synthetic solution or oil Solution entièrement synthétique ou huile	
Scheibenspezifikation Wheel specification Spécification de la meule			
Körnungsgröße Grit size Granulation		D 46 – D 76	B 91 – B 151
Konzentration Concentration Concentration		100	75 (100)
Bindung Bond Liant		K833N, K850R	K833N, K850R

Einsatzempfehlungen für verschiedene Schleifverfahren
Recommendations for different grinding operations
Instructions générales pour diverses opérations de rectification

Werkzeugschleifen / Tool and cutter grinding / Affûtage d'outil			
Trockenschleifen Dry grinding Rectificatin à sec		Diamant Diamond Diamant	Bornitrid Boron nitride Nitrure de bore
Schnittgeschwindigkeit Schleifscheibe Wheel peripheral speed Vitesse de coupe de la meule	v_c m/s	12 – 18	15 – 22, K300J, K300N 25 – 40, K303P
Zustellung Infeed Profondeur de passe	a_e mm	0,01 – 0,03	0,2 – 0,3
Werkstückvorschub Feed rate Avance de la pièce	v_{fa} mm/min		manuell manual manuel
Scheibenspezifikation Wheel specification Spécification de la meule			
Körnunggröße Grit size Granulation		D 91 – D 151	B 107 – B 181
Konzentration Concentration Concentration		75	75
Bindung Bond Liant		K200N, K200R	K300J, K303P, K300N
Naßschleifen Wet grinding Rectification sous arrosage		Diamant Diamond Diamant	Bornitrid Boron nitride Nitrure de bore
Schnittgeschwindigkeit Schleifscheibe Wheel peripheral speed Vitesse de coupe de la meule	v_c m/s	15 – 25	22 – 35
Zustellung Infeed Profondeur de passe	a_e mm	0,3 – 4,0	0,4 – 4,0
Werkstückvorschub Feed rate Avance de la pièce	v_{fa} mm/min	20 – 150	30 – 300
Kühlung Coolant Refroidissement		Vollsynthetische Lösung oder Öl Fully synthetic solution or oil Solution entièrement synthétique ou huile	
Scheibenspezifikation Wheel specification Spécification de la meule			
Körnunggröße Grit size Granulation		D 76 – D 151	B 107 – B 151
Konzentration Concentration Concentration		100	100 (125)
Bindung Bond Liant		K450R, K850R, K833N	K833N, K850R

Einsatzempfehlungen für verschiedene Schleifverfahren
Recommendations for different grinding operations
Instructions générales pour diverses opérations de rectification

Werkzeugschleifen/Tool and cutter grinding/Affûtage d'outil			
Trennen Cutting-off Tronçonnage		Diamant Diamond Diamant	Bornitrid Boron nitride Nitrure de bore
Schnittgeschwindigkeit Trennscheibe Cutting-off speed Vitesse de coupe du disque à tronçonner	trocken dry v_c m/s à sec	15 – 18	20 – 25
Schnittgeschwindigkeit Trennscheibe Cutting-off speed Vitesse de coupe du disque à tronçonner	naß wet v_c m/s sous arrosage	25 – 35	25 – 40
Werkstückgeschwindigkeit Work piece speed Vitesse de la pièce	v_w m/min	0 – 10	0 - 10
Werkstückvorschub Feed rate Avance de la pièce	trocken dry v_{fa} mm/min à sec	10 – 50	10 – 50
Werkstückvorschub Feed rate Avance de la pièce	naß wet v_{fa} mm/min sous arrosage	10 – 200	10 – 200
Zustellung Infeed Profondeur de passe	trocken dry a_e mm à sec	0,1 – 2,0	0,1 – 2,0
Zustellung Infeed Profondeur de passe	naß wet a_e mm sous arrosage	10 – 200	10 – 200
Kühlung Coolant Refroidissement			Emulsion oder Öl Emulsion or oil Emulsion ou huile
Scheibenspezifikation Wheel specification Spécification de la meule			
Körnungsgröße Grit size Granulation		D 126, D 151	B 126 – B 151
Konzentration Concentration Concentration		75/100	75/100
Bindung Bond Liant	trocken dry à sec	K200N	K300N
Bindung Bond Liant	naß wet sous arrosage	K400NT / K410R	K500NT / K510R

Flachschleifen, Außenrundscheifen

Surface grinding, OD grinding

Rectification de surfaces planes et de surfaces extérieures cylindriques

1A1

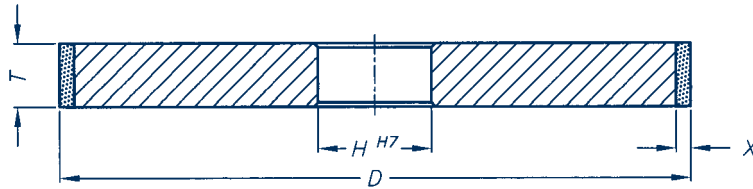

3A1

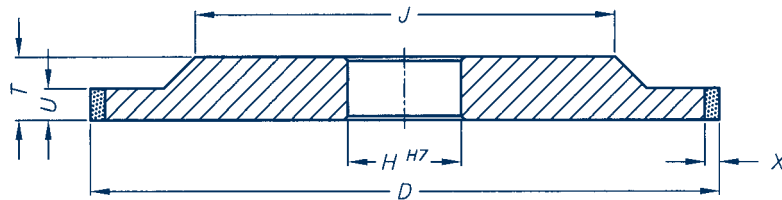

14A1

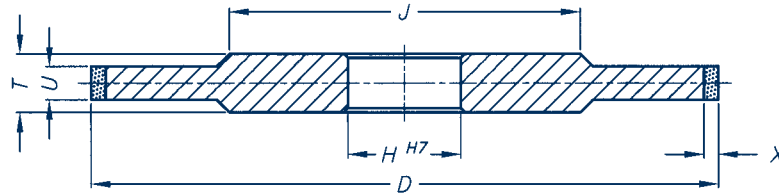

D mm	T/U mm	X mm	J mm	H mm
200	5 - 30	2 - 5	160	51, 76
225	5 - 30	2 - 5	180	51, 76
250	5 - 30	2 - 5	200	51, 76
300	5 - 30	2 - 5	240	76, 127
350	5 - 30	2 - 5	280	127
400	5 - 30	2 - 5	320	127

Andere Maße auf Anfrage/Other dimensions on request/Autres dimensions sur demande

Bestellbeispiel Order example Exemple de commande	Form Shape Forme	D mm	T mm	X mm	H mm	Körnungsgröße Grit size Granulation	Bindung Bond Liant	Konzentration Concentration Concentration
	1A1	225	10	2	51	D 126	K400JB	75

Werkzeugschleifen Tool and cutter grinding Affûtage d'outils

4Q9

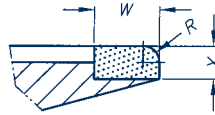

für positive Spanwinkel und enge Teilung
for positive rake angle and tight pitch
pour angle de coupe positif et pas étroit

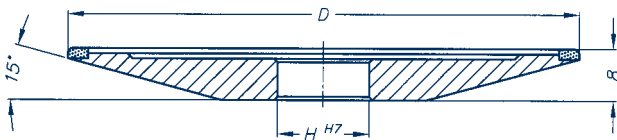

D mm	W mm	X mm	R mm	H mm
75	4	1	0,5	nach Angabe as specified selon spécification
75	4	2	0,5	
100	4	1	0,5	
100	4	2	0,5	

Bestellbeispiel Order example Exemple de commande	Form	D	W	X	R	H	Körnungsgröße	Bindung	Konzentration
	Shape	mm	mm	mm	mm	mm	Grit size	Bond	Concentration
	Forme	mm	mm	mm	mm	mm	Granulation	Liant	Concentration
4Q9		100	4	2	0,5	20	D 126	K200R	75

4CH9

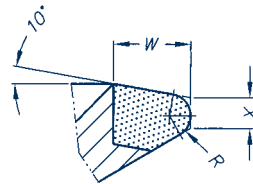

für negative Spanwinkel
for negative rake angle
pour angle de coupe négatif

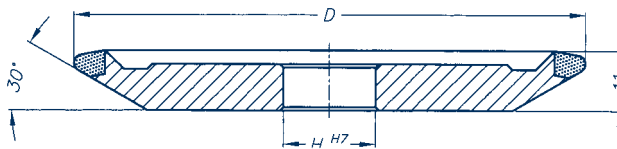

D mm	W mm	X mm	R mm	H mm
75	4	2	1,4	nach Angabe as specified selon spécification
100	4	2	1,4	
125	4	2	1,4	

Bestellbeispiel Order example Exemple de commande	Form	D	W	X	R	H	Körnungsgröße	Bindung	Konzentration
	Shape	mm	mm	mm	mm	mm	Grit size	Bond	Concentration
	Forme	mm	mm	mm	mm	mm	Granulation	Liant	Concentration
4CH9		75	4	2	1,4	20	B 126	K300N	75

11V9

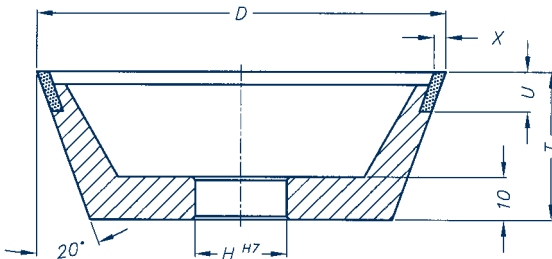

für das Nachschärfen der Stirnfläche und Freiwinkel,
halbieren von Stichel
for resharping the front milling and the clearance angle,
for forming single-lip cutters
pour réaffûter la surface extérieure et la dépouille,
partager en deux des outil de tournage

D mm	X mm	U mm	T mm	H mm
75	2	10	30	nach Angabe as specified selon spécification
100	2	10	35	
100	3	10	35	
125	2	10	40	
125	3	10	40	

Bestellbeispiel Order example Exemple de commande	Form	D	X	U	H	Körnungsgröße	Bindung	Konzentration
	Shape	mm	mm	mm	mm	Grit size	Bond	Concentration
	Forme	mm	mm	mm	mm	Granulation	Liant	Concentration
11V9		100	2	10	20	B 126	K303P	75

12V9-45°

für das Nachschärfen der Spannutt und des Freiwinkels
for resharpening the flute and the clearance angle
pour réaffûter la rainure à copeaux et la dépouille

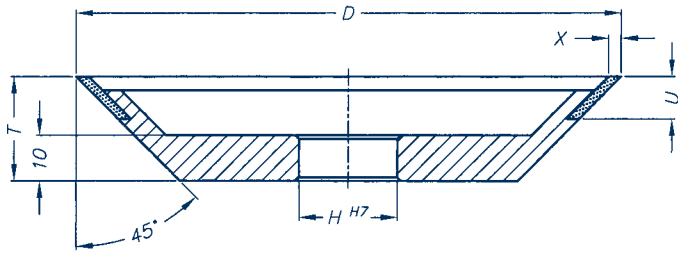

D mm	X mm	U mm	T mm	H mm
75	2	10	20	nach Angabe as specified selon spécification
100	2	10	20	
100	2	10	20	
125	2	10	25	
125	3	10	25	

Bestellbeispiel
Order example
Exemple de commande

Form Shape Forme	D mm	X mm	U mm	T mm	H mm	Körnungsgröße Grit size Granulation	Bindung Bond Liant	Konzentration Concentration Concentration
12V9-45°	75	2	10	20	20	D 126	K200R	75

1A1

Tiefschliff der Stirnschneide und Schneidenfase aus dem Vollen
Deep grinding from solid of the face and chamfer of cutters
Rectification dans la masse de la face d'attaque et de dépouille

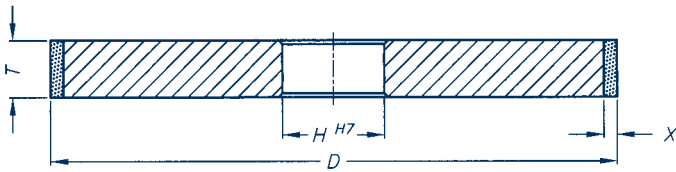

D mm	T mm	X mm	H mm
100	4-12	5+10	nach Angabe as specified selon spécification
125	4-12	5+10	
150	4-12	5+10	

Andere Maße auf Anfrage/Other dimensions on request/Autres dimensions sur demande

Bestellbeispiel
Order example
Exemple de commande

Form Shape Forme	D mm	T mm	X mm	H mm	Körnungsgröße Grit size Granulation	Bindung Bond Liant	Konzentration Concentration Concentration
1A1	125	6	5	20	B 91	K833N	100

1V1

Tiefschliff der Spanfläche und Spannutt aus dem Vollen
sowie Ausspitzen der Stirnschneide
Deep grinding from the solid of face and flute as well as undercutting of the front cutter
Rectification dans la masse des facettes de la face de coupe et de dépouille avec amincissement de la face d'attaque

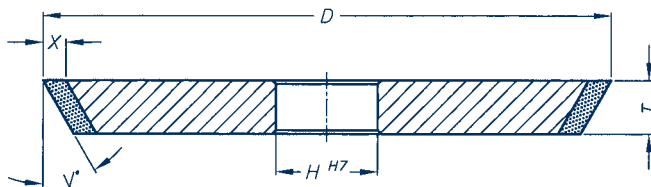

D mm	T mm	X mm	V°	H mm
100	4-12	5+10	15°/30°/45°	nach Angabe as specified selon spécification
125	4-12	5+10		
150	4-12	5+10		

Andere Maße auf Anfrage/Other dimensions on request/Autres dimensions sur demande

Bestellbeispiel
Order example
Exemple de commande

Form Shape Forme	D mm	T mm	X mm	V°	H mm	Körnungsgröße Grit size Granulation	Bindung Bond Liant	Konzentration Concentration Concentration
1V1	150	12	5	15	20	D 64	K833N	100

6A2

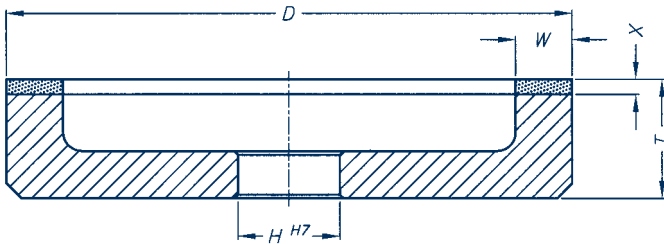

Neu- und Nachschliff polykristalliner Diamant- und CBN-Schneiden
Edge grinding and edge sharpening of polycrystalline diamond and boron nitride cutters
Affûter et réaffûter des plaquettes en diamant et nitrure de bore polycristalline

D mm	W mm	X mm	T mm	H mm
150	4/6 10/20	4 6 8	40	nach Angabe as specified selon spécification

Bestellbeispiel Order example Exemple de commande	Form	D	W	X	H	Körnungsgröße	Bindung
	Shape	mm	mm	mm	mm	Grit size	Bond
	Forme	mm	mm	mm	mm	Granulation	Liant
6A2		150	20	4	32	D 20	M925J

12A2-45°

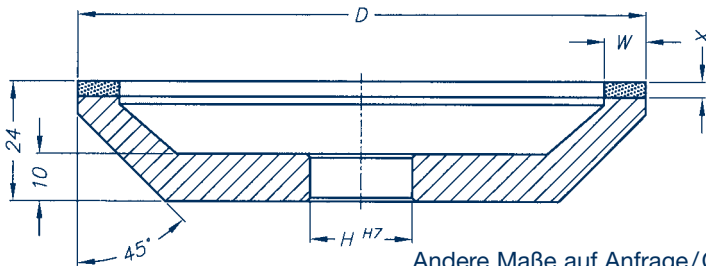

für das Nachschleifen von HM-Stichel
for resharpening of single-lip TC cutters
pour réaffûter les outils à graver en métal dur

D mm	W mm	X mm	H mm
100	8	2	nach Angabe as specified selon spécification

Andere Maße auf Anfrage/Other dimensions on request/Autres dimensions sur demande

Bestellbeispiel Order example Exemple de commande	Form	D	W	X	H	Körnungsgröße	Bindung	Konzentration
	Shape	mm	mm	mm	mm	Grit size	Bond	Concentration
	Forme	mm	mm	mm	mm	Granulation	Liant	Concentration
12A2-45°		100	8	2	20	D 64	K200N	50

14F1

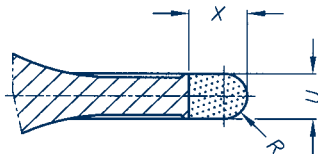

Profilschleifen von Formfräsern auf Loroch- und Schmidt-Tempo-Maschinen
Profile grinding of form cutters on Loroch and Schmidt-Tempo machines
Rectification des fraises à profiler sur machines Loroch et Schmidt-Tempo

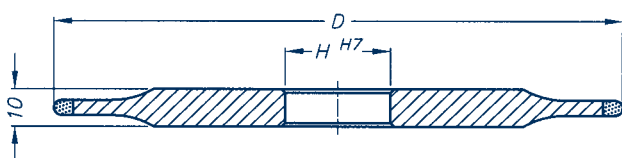

D mm	U mm	X mm	R mm	H mm
150 u. 200	1,3 2,0 2,5 3,0	8 8 8 8	0,65 1,0 1,25 1,5	nach Angabe as specified selon spécification

Bestellbeispiel Order example Exemple de commande	Form	D	U	X	R	H	Körnungsgröße	Bindung	Konzentration
	Shape	mm	mm	mm	mm	mm	Grit size	Bond	Concentration
	Forme	mm	mm	mm	mm	mm	Granulation	Liant	Concentration
14F1		150	2	8	1	25	D 126	K200RA	100

1A1R

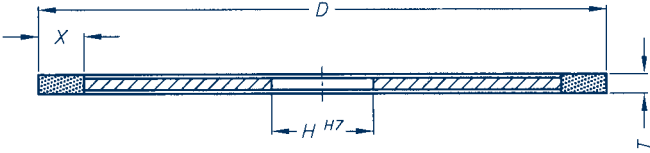

Trennen von Hartmetall oder hochlegierten Stählen
Cutting of TC or high alloy steels
Tronçonner de métal dur ou d'aciers fortement alliés

D mm	T mm	X mm	H mm
100	1,0	5	20
150	1,0	8	20
200	1,2	8	20

Andere Abmessungen auf Anfrage
Other dimensions on request
Autre dimensions sur demande

Bestellbeispiel Order example Exemple de commande	Form Shape Forme	D mm	T mm	X mm	H mm	Körnungsgröße Grit size Granulation	Bindung Bond Liant	Konzentration Concentration Concentration
	1A1R	150	1	8	20	D 151	K400NT	100

6A2/135

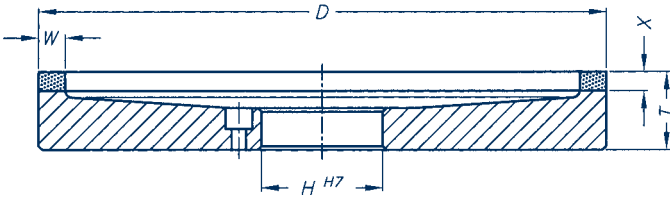

Schleifen von Papiermessern auf Göckel- und Reform-Maschinen
Grinding of paper knives on Göckel and Reform machines
Rectification des couteaux à papier sur machines Göckel et Reform

D mm	W mm	X mm	T mm	H mm
200	6-8	4	29	nach Angabe as specified selon spécification
200	6-8	6	31	
250	6-8	4	29	
250	6-8	6	31	

Bestellbeispiel Order example Exemple de commande	Form Shape Forme	D mm	W mm	X mm	H mm	Körnungsgröße Grit size Granulation	Bindung Bond Liant	Konzentration Concentration Concentration
	6A2/135	200	6	6	75	D 126	K400J	100

Einsatzempfehlungen für das Schleifen von Kreissägen Recommendations for saw sharpening Instructions générales pour l'affûtage des scies

Sägenschärfen – Brustschliff / Saw sharpening – face grinding / Affûtage des scies – rectification de face			
Schliff des Spanwinkels Grinding of the rake angle Rectification de l'angle de coupe	Schliff des Schrägwinkels Grinding of the inclined angle Rectification de l'angle incliné		
18° bis 45° 18° to 45° 18° à 45°	0° bis 30° 0° to 30° 0° à 30°		
Pendelschleifen / Oscillation grinding / Rectification oscillante			
Zustellung pro Doppelhub Infeed per double pass Profondeur de passe par double course	Arbeitsgeschwindigkeit Cutting speed Vitesse de coupe	Hubzahl (Oszillation) pro Minute Number of strokes (oscillations) per minute Nombre de courses (oscillations) par minute	
0,02 – 0,04 mm	18 – 23 m/s	60 – 120	
Kühlmittel Coolant Refroidissement	Diamant Diamond Diamant	Bornitrid Boron nitride Nitrure de bore	
	Emulsion 1 : 30 – 50 Emulsion 1 : 30 – 50 Emulsion 1 : 30 – 50	Emulsion 1 : 20 – 40 mit EP-Zusatz Emulsion 1 : 20 – 40 with EP additives Emulsion 1 : 20 – 40 avec additifs EP	
Tiefschleifen / Deep grinding / Rectification en plongée			
Zustellung pro Hub Infeed per pass Profondeur de passe par course	Arbeitsgeschwindigkeit Cutting speed Vitesse de coupe	Vorschubgeschwindigkeit Feed rate Vitesse d'avance	Taktzeit (Vorschubzeit und Schleifzeit) Cycle time (infeed time and grinding time) Temps de cycle (Temps d'avance et temps de rectification)
0,3 – 1,5 mm	18 – 23 m/s	50 – 200 mm/min	6 – 9 sec/Zahn 6 – 9 sec/tooth 6 – 9 sec/dent
Kühlmittel Coolant Refroidissement	Diamant Diamond Diamant	Bornitrid Boron nitride Nitrure de bore	
	Emulsion 1 : 30 – 50 Emulsion 1 : 30 – 50 Emulsion 1 : 30 – 50	Emulsion 1 : 20 – 40 mit EP-Zusatz Emulsion 1 : 20 – 40 with EP additives Emulsion 1 : 20 – 40 avec additifs EP	

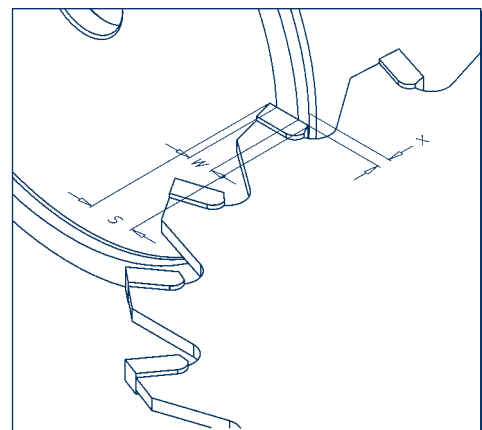
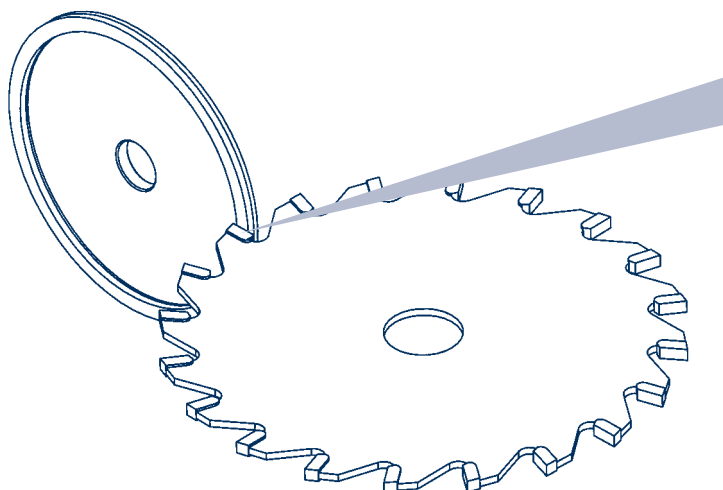

Die Belagbreite (W) der Schleifscheibe sollte kleiner als die Zahnhöhe sein.
 The rim width (W) of the grinding wheel should be smaller than the depth of the tooth.
 La largeur de la surface abrasive (W) doit être plus petite que la hauteur de la dent.

Brustschliff im Pendelschleifverfahren von HM-bestückten Sägen
Oscillation face grinding of TC tipped saws
Rectification oscillante de face des lames de scies plaquette en métal dur

Diamant-Schleifscheiben/Diamond grinding wheels/Meules diamant

4A2/92

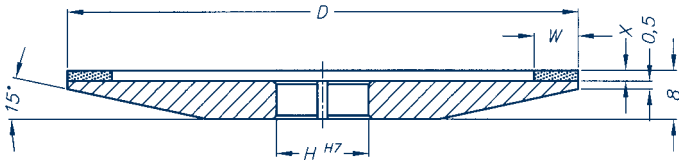

Enge Teilung/Narrow pitch/Pas étroit

D mm	W mm	X mm	H mm
100	4	1	nach Angabe as specified selon spécification
100	5	1	

Körnungsgröße Grit size Granulation	Bindung Bond Liant	Konzentration Concentration Concentration
D 64	K200N	75
D 64	K200N	100

Bestellbeispiel Order example Exemple de commande	Form Shape Forme	D mm	W mm	X mm	H mm	Körnungsgröße Grit size Granulation	Bindung Bond Liant	Konzentration Concentration Concentration
	4A2/92	100	4	1	25	D 64	K200N	75

4A2/102

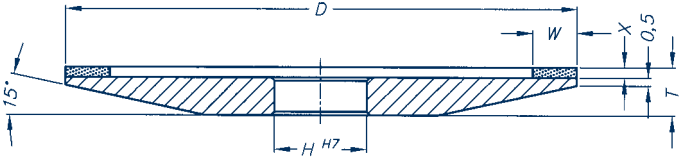

Mittlere Teilung/Medium pitch/Pas moyen

D mm	W mm	X mm	T mm	H mm
100	5	2	10	nach Angabe as specified selon spécification
125	5	2	10	
150	5	4	13	
175	5	4	13	

Körnungsgröße Grit size Granulation	Bindung Bond Liant	Konzentration Concentration Concentration
D 46	K200N	50
D 46	K200N	75
D 64	K200N	50
D 64	K200N	75

Bestellbeispiel Order example Exemple de commande	Form Shape Forme	D mm	W mm	X mm	H mm	Körnungsgröße Grit size Granulation	Bindung Bond Liant	Konzentration Concentration Concentration
	4A2/102	125	5	2	20	D 46	K200N	50

12A2/103

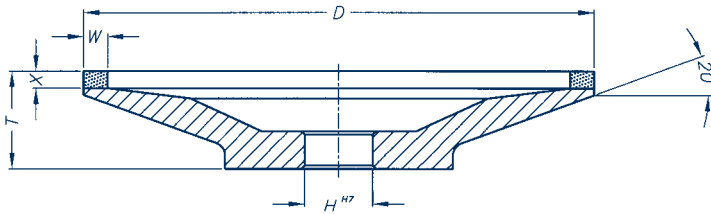

Weite Teilung/Large pitch/Pas grand

D mm	W mm	X mm	T mm	H mm
125	5	2	23	nach Angabe as specified selon spécification
125	5	4	23	
150	5	4	23	
175	5	4	26	

Körnungsgröße Grit size Granulation	Bindung Bond Liant	Konzentration Concentration Concentration
D 126	K200N	50 oder 75
D 91	K200N	50 oder 75
D 64	K200N	50
D 35	K200N	50

Bestellbeispiel Order example Exemple de commande	Form	D	W	X	H	Körnungsgröße	Bindung	Konzentration
	Shape	mm	mm	mm	mm	Grit size	Bond	Concentration
	Forme	mm	mm	mm	mm	Granulation	Liant	Concentration
	12A2/103	125	5	2	20	D 126	K200N	50

12A2/104

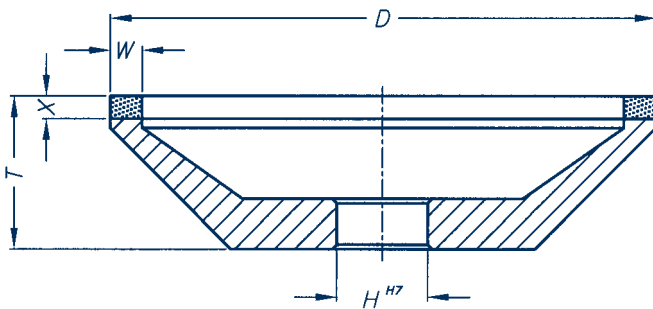

Weite Teilung/Large pitch/Pas grand

D mm	W mm	X mm	T mm	H mm
100	6	4	27	nach Angabe as specified selon spécification

Körnungsgröße Grit size Granulation	Bindung Bond Liant	Konzentration Concentration Concentration
D 64	K200R	50
D 91	K200R	50 oder 75
D 126	K200R	50 oder 75

Bestellbeispiel Order example Exemple de commande	Form	D	W	X	H	Körnungsgröße	Bindung	Konzentration
	Shape	mm	mm	mm	mm	Grit size	Bond	Concentration
	Forme	mm	mm	mm	mm	Granulation	Liant	Concentration
	12A2/104	100	6	4	20	D 64	K200R	50

Brustschliff im Tiefschleifverfahren von HM-bestückten Sägen

Deep grinding of TC tipped saws

Rectification en plongée de face des lames de scies plaquette en métal dur

Diamant-Schleifscheiben/Diamond grinding wheels/Meules diamant

4B9/123

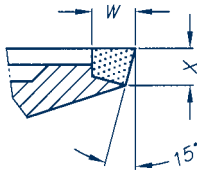

Enge und engste Teilung/Narrow and tightest pitch/Pas étroit et le plus étroit

D mm	W mm	X mm	H mm
100	2	1,5	nach Angabe as specified selon spécification

Körnungsgröße Grit size Granulation	Bindung Bond Liant	Konzentration Concentration Concentration
D 64	K850R	100
D 64	K850R	125
D 35	K850R	100

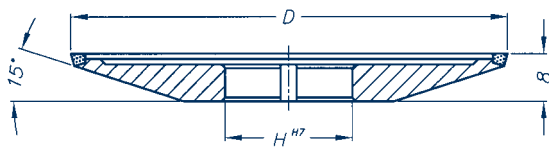

Bestellbeispiel Order example Exemple de commande	Form Shape Forme	D mm	W mm	X mm	H mm	Körnungsgröße Grit size Granulation	Bindung Bond Liant	Konzentration Concentration Concentration
	4B9/123	100	2	1,5	25	D 64	K850R	100

4B9/131

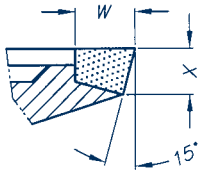

Enge Teilung/Narrow pitch/Pas étroit

D mm	W mm	X mm	H mm
100	3	1,8	nach Angabe as specified selon spécification

Körnungsgröße Grit size Granulation	Bindung Bond Liant	Konzentration Concentration Concentration
D 64	K850R	75
D 64	K850R	125
D 46	K850R	75
D 46	K850R	100

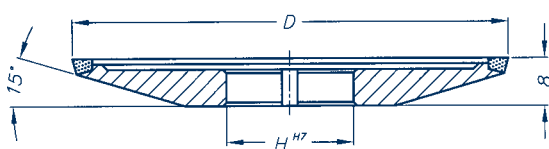

Bestellbeispiel Order example Exemple de commande	Form Shape Forme	D mm	W mm	X mm	H mm	Körnungsgröße Grit size Granulation	Bindung Bond Liant	Konzentration Concentration Concentration
	4B9/131	100	3	1,8	25	D 64	K850R	125

4B9/132

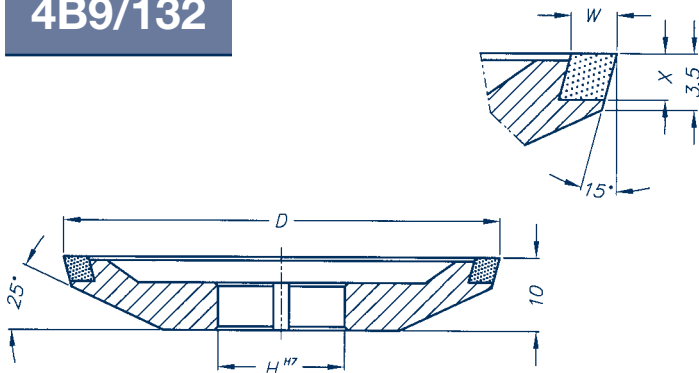

Weite Teilung/Large pitch/Pas grand

D mm	W mm	X mm	H mm
100	3	3	nach Angabe as specified selon spécification

Körnungsgröße Grit size Granulation	Bindung Bond Liant	Konzentration Concentration Concentration
D 46	K850R	75 (100)
D 54	K850R	75 (125)
D 64	K850R	75 (100)

Bestellbeispiel Order example Exemple de commande	Form Shape Forme	D mm	W mm	X mm	H mm	Körnungsgröße Grit size Granulation	Bindung Bond Liant	Konzentration Concentration Concentration
	4B9/132	100	3	3	25	D 54	K850R	100

12V9/133

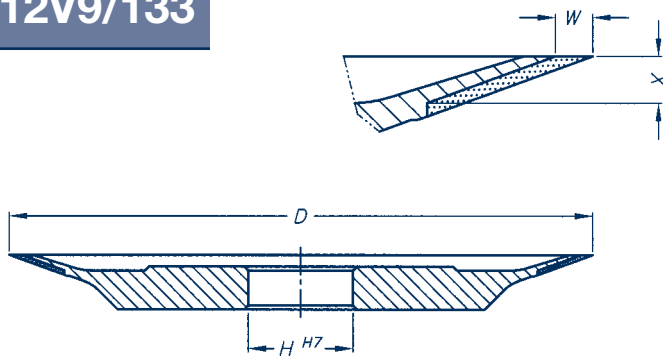

D mm	W mm	X mm	H mm
100	2,3	4	nach Angabe as specified selon spécification
125	2,3	4	
150	2,3	4	
155	2,3	4	
200	2,3	4	

Bestellbeispiel Order example Exemple de commande	Form Shape Forme	D mm	W mm	X mm	H mm	Körnungsgröße Grit size Granulation	Bindung Bond Liant	Konzentration Concentration Concentration
	12V9/133	125	2,3	4	25	nach Einsatzzweck / To be advised (tba) / Suivant utilisation		

Brustschliff im Tiefschleifverfahren von HM-bestückten Sägen

Deep grinding of the face of TC tipped saws

Rectification en plongée de face des lames de scies plaquette en métal dur

Diamant-Schleifscheiben/Diamond grinding wheels/Meules diamant

4B9/141

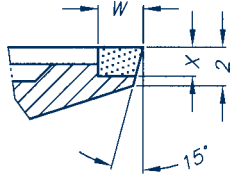

Engste Teilung/Tightest pitch/Pas le plus étroit

D mm	W mm	X mm	H mm
125	2,5	1,2	nach Angabe as specified selon spécification

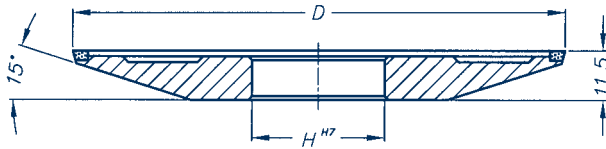

Körnungsgröße Grit size Granulation	Bindung Bond Liant	Konzentration Concentration Concentration
D 54	K850R	125
D 54	K850R	100
D 54	K850R	75

Bestellbeispiel Order example Exemple de commande	Form Shape Forme	D mm	W mm	X mm	H mm	Körnungsgröße Grit size Granulation	Bindung Bond Liant	Konzentration Concentration Concentration
	4B9/141	125	2,5	1,2	32	D 54	K850R	75

4B9/142

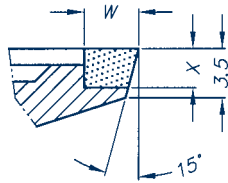

Mittlere Teilung/Medium pitch/Pas moyen

D mm	W mm	X mm	H mm
125	3	1,8	nach Angabe as specified selon spécification

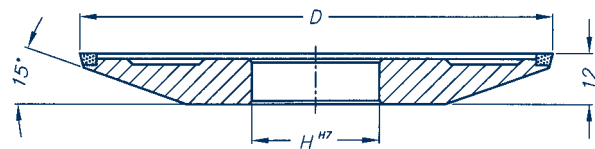

Körnungsgröße Grit size Granulation	Bindung Bond Liant	Konzentration Concentration Concentration
D 54	K850R	75
D 54	K850R	100

Bestellbeispiel Order example Exemple de commande	Form Shape Forme	D mm	W mm	X mm	Körnungsgröße Grit size Granulation	Bindung Bond Liant	Konzentration Concentration Concentration
	4B9/142	125	3	1,8	D 54	K850R	100

4B9/143

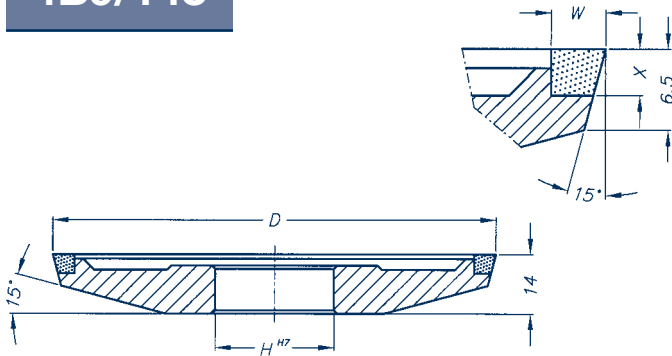

Weite Teilung/Large pitch/Pas grand

D mm	W mm	X mm	H mm
125	3	3,8	nach Angabe as specified selon spécification

Körnungsgröße Grit size Granulation	Bindung Bond Liant	Konzentration Concentration Concentration
D 54 D 54	K850R K850R	75 100

Bestellbeispiel Order example Exemple de commande	Form Shape Forme	D mm	W mm	X mm	H mm	Körnungsgröße Grit size Granulation	Bindung Bond Liant	Konzentration Concentration Concentration
4B9/143	4B9/143	125	3	3,8	32	D 54	K850R	75

1A1W

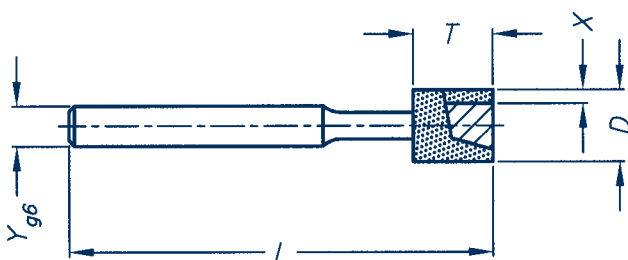

Zum Schleifen der Zahnbrust an Holzsägen im Tiefschliff
For deep grinding the face of saws with hollow teeth
Rectification en plongée de la face d'attaque des dents creuses de scies

D mm	T mm	X mm	Y mm	L mm
6,5	3	1,75	6	45
7,0	3	2,00	6	45

Körnungsgröße Grit size Granulation	Bindung Bond Liant	Konzentration Concentration Concentration
D 76 D 91 D 151	K400N K400N K400N	125 125 125

Bestellbeispiel Order example Exemple de commande	Form Shape Forme	D mm	T mm	X mm	Y mm	L mm	Körnungsgröße Grit size Granulation	Bindung Bond Liant	Konzentration Concentration Concentration
1A1W	1A1W	6,5	3	1,75	6	45	D 76	K400N	125

Brustschliff im Tiefschleifverfahren von HM-bestückten Sägen

Deep grinding of the face of TC tipped saws

Rectification en plongée de face des lames de scies plaquette en métal dur

Diamant-Schleifscheiben/Diamond grinding wheels/Meules diamant

4B9/161

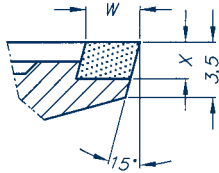

Enge Teilung/Narrow pitch/Pas étroit

D mm	W mm	X mm	H mm
150	3	1,8	nach Angabe as specified selon spécification

Körnungsgröße Grit size Granulation	Bindung Bond Liant	Konzentration Concentration Concentration
D 54	K850R	100

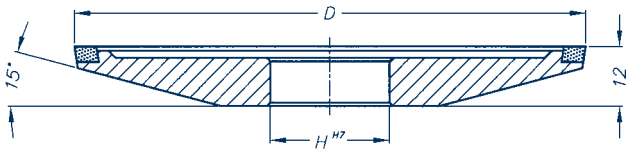

Bestellbeispiel Order example Exemple de commande	Form Shape Forme	D mm	W mm	X mm	H mm	Körnungsgröße Grit size Granulation	Bindung Bond Liant	Konzentration Concentration Concentration
	4B9/161	150	3	1,8	32	D 54	K850R	100

4B9/162

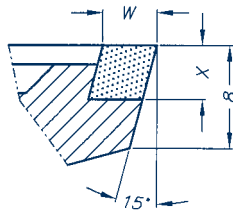

Normale und weite Teilung
Medium and large pitch
Pas moyen et grand

D mm	W mm	X mm	H mm
150	3	3,8	nach Angabe as specified selon spécification

Körnungsgröße Grit size Granulation	Bindung Bond Liant	Konzentration Concentration Concentration
D 54	K850R	100

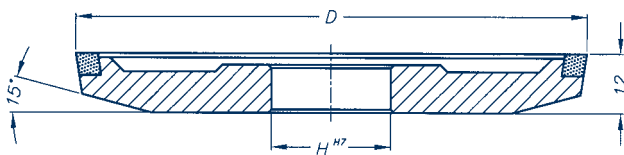

Bestellbeispiel Order example Exemple de commande	Form Shape Forme	D mm	W mm	X mm	H mm	Körnungsgröße Grit size Granulation	Bindung Bond Liant	Konzentration Concentration Concentration
	4B9/162	150	3	3,8	32	D 54	K850R	100

12V2/163

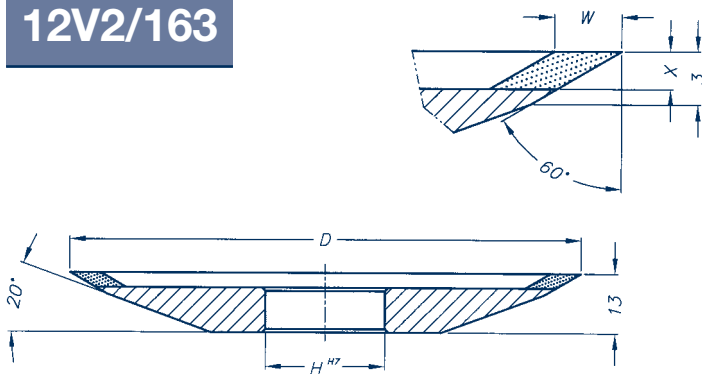

Enge Teilung/Narrow pitch/Pas étroit

D mm	W mm	X mm	H mm
100	4	2	nach Angabe as specified selon spécification
125	4	2	
200	4	2	

Körnungsgröße Grit size Granulation	Bindung Bond Liant	Konzentration Concentration Concentration
D 76 D 76	K850R K850R	100 125

Bestellbeispiel Order example Exemple de commande	Form Shape Forme	D mm	W mm	X mm	H mm	Körnungsgröße Grit size Granulation	Bindung Bond Liant	Konzentration Concentration Concentration
	12V2/163	125	4	2	32	D 76	K850R	125

4A2/133

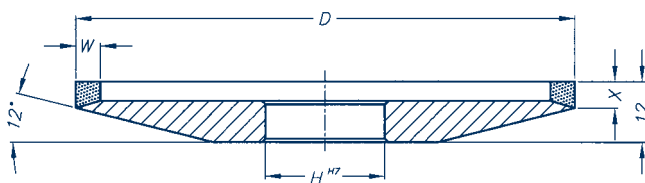

Normale und weite Teilung
Medium and large pitch
Pas moyen et grand

D mm	W mm	X mm	H mm
150	3	3,5	nach Angabe as specified selon spécification
175	3	3,5	
200	3	3,5	

Körnungsgröße Grit size Granulation	Bindung Bond Liant	Konzentration Concentration Concentration
D 46	K850R	75

Bestellbeispiel Order example Exemple de commande	Form Shape Forme	D mm	W mm	X mm	H mm	Körnungsgröße Grit size Granulation	Bindung Bond Liant	Konzentration Concentration Concentration
	4A2/133	150	3	3,5	20	D 46	K850R	75

Brustschliff im Pendelschleifverfahren von Sägen und Fräsern aus HSS
Oscillation face grinding of high speed steel saws and milling cutters
Rectification oscillante de face des lames de scies et fraises d'acier à coupe rapide

Bornitrid-Schleifscheiben/Boron nitride grinding wheels/Meules nitrure de bore

12A2/251

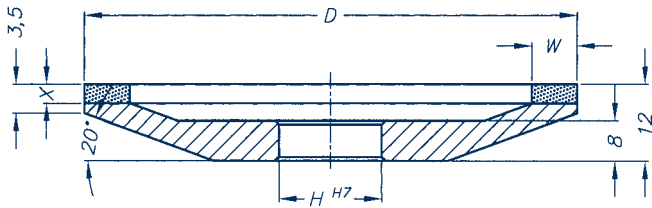

Schleifen der Zahnbrust und des Zahnrückens
 Grinding the face and back of the cutting teeth
 Rectification de la face d'attaque et du dos de la dent

D mm	W mm	X mm	H mm
100	5	2	nach Angabe as specified selon spécification

Körnungsgröße Grit size Granulation	Bindung Bond Liant	Konzentration Concentration Concentration
B 126	K300J	50

Bestellbeispiel Order example Exemple de commande	Form Shape Forme	D mm	W mm	X mm	H mm	Körnungsgröße Grit size Granulation	Bindung Bond Liant	Konzentration Concentration Concentration
	12A2/251	100	5	2	32	B 126	K300J	50

12A2/252

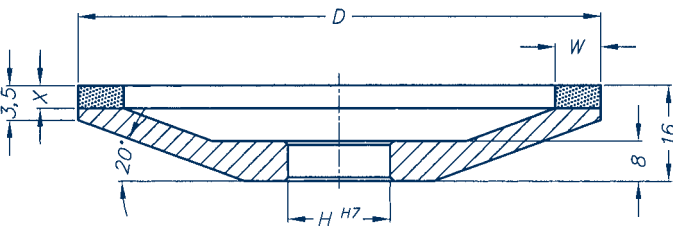

Schleifen der Zahnbrust und des Zahnrückens
 Grinding the face and back of the cutting teeth
 Rectification de la face d'attaque et du dos de la dent

D mm	W mm	X mm	H mm
125	5	2	nach Angabe as specified selon spécification
125	5	4	

Körnungsgröße Grit size Granulation	Bindung Bond Liant	Konzentration Concentration Concentration
B 126	K300J	50

Bestellbeispiel Order example Exemple de commande	Form Shape Forme	D mm	W mm	X mm	H mm	Körnungsgröße Grit size Granulation	Bindung Bond Liant	Konzentration Concentration Concentration
	12A2/252	125	5	2	20	B 126	K300J	50

12A2/253

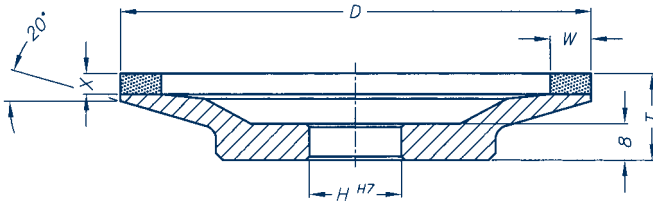

Schleifen der Zahnbrust und des Zahnrückens an Fräswerkzeugen sowie der Zahnbrust an weitverzahnten Sägen
 Grinding the face and back of the cutting teeth of milling cutters as well as grinding the cutting teeth of wide toothed saws
 Rectification de la face d'attaque et du dos de la dent des fraises aussi que la face d'attaque des lames de scies avec des dents espacées

D mm	W mm	X mm	H mm
125	5	2	nach Angabe as specified
125	5	4	selon spécification

Körnungsgröße Grit size Granulation	Bindung Bond Liant	Konzentration Concentration Concentration
B 91	K300J	50
B 107	K300J	50
B 126	K300J	50
B 151	K300J	50

Bestellbeispiel Order example Exemple de commande	Form	D	W	X	H	Körnungsgröße	Bindung	Konzentration
	Shape	mm	mm	mm	mm	Grit size	Bond	Concentration
	Forme	mm	mm	mm	mm	Granulation	Liant	Concentration
12A2/253	125	5	2	20	B 126	K300J	50	

Brustschliff im Tiefschleifverfahren von Sägen und Fräsern aus HSS
Deep grinding the face of high speed steel saws and milling cutters
Rectification en plongée de face des lames de scies et fraises en acier à coupe rapide

Bornitrid-Schleifscheiben/Boron nitride grinding wheels/Meules nitrure de bore

4B9/261

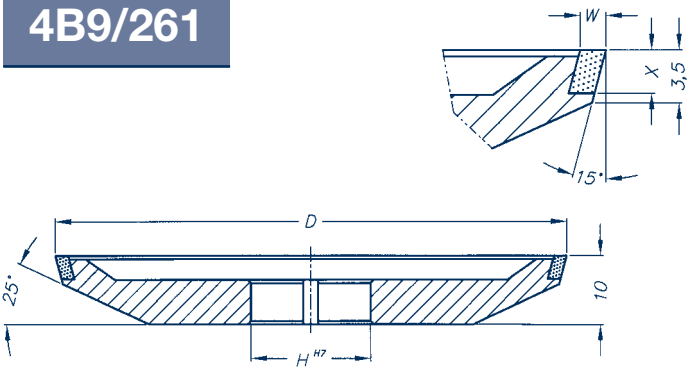

Enge Teilung/Narrow pitch/Pas étroit

D mm	W mm	X mm	H mm
100	1,5	3	nach Angabe as specified selon spécification

Körnungsgröße Grit size Granulation	Bindung Bond Liant	Konzentration Concentration Concentration
B 126 B 126	K833N K833N	75 100

Bestellbeispiel Order example Exemple de commande	Form Shape Forme	D mm	W mm	X mm	H mm	Körnungsgröße Grit size Granulation	Bindung Bond Liant	Konzentration Concentration Concentration
	4B9/261	100	1,5	3	25	B 126	K833N	100

4B9/262

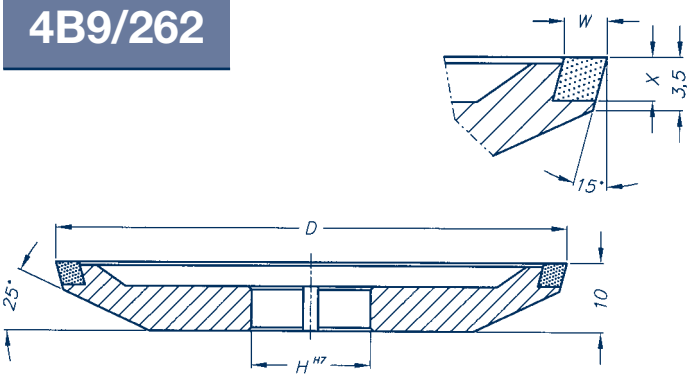

Normale Teilung/Normal pitch/Pas normal

D mm	W mm	X mm	H mm
100	3	3	nach Angabe as specified selon spécification

Körnungsgröße Grit size Granulation	Bindung Bond Liant	Konzentration Concentration Concentration
B 126 B 126	K833N K833N	75 100

Bestellbeispiel Order example Exemple de commande	Form Shape Forme	D mm	W mm	X mm	H mm	Körnungsgröße Grit size Granulation	Bindung Bond Liant	Konzentration Concentration Concentration
	4B9/262	100	3	3	20	B 126	K833N	100

4B9/263

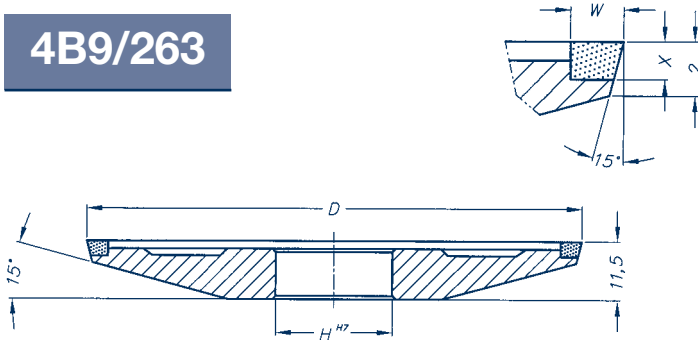

Engste Teilung/Tighest pitch/Pas le plus étroit

D mm	W mm	X mm	H mm
125	2,5	1,2	nach Angabe as specified selon spécification

Körnungsgröße Grit size Granulation	Bindung Bond Liant	Konzentration Concentration Concentration
B 91	K833N	75, 100
B 91	K833N	75, 100
B 91	K833N	75, 100

Bestellbeispiel Order example Exemple de commande	Form	D	W	X	H	Körnungsgröße	Bindung	Konzentration
	Shape	mm	mm	mm	mm	Grit size	Bond	Concentration
	Forme	mm	mm	mm	mm	Granulation	Liant	Concentration
	4B9/263	125	2,5	1,2	32	B 91	K833N	100

4B9/264

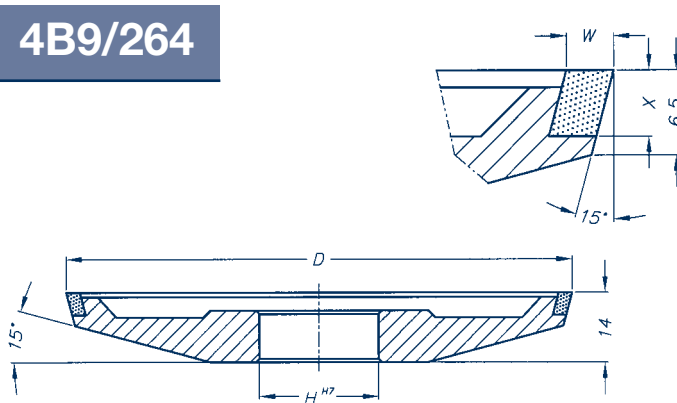

Normale und weite Teilung
Medium and large pitch
Pas moyen et grand

D mm	W mm	X mm	H mm
125	3	3,8	nach Angabe as specified selon spécification

Körnungsgröße Grit size Granulation	Bindung Bond Liant	Konzentration Concentration Concentration
B 126	K833N	75
B 126	K833N	100

Bestellbeispiel Order example Exemple de commande	Form	D	W	X	H	Körnungsgröße	Bindung	Konzentration
	Shape	mm	mm	mm	mm	Grit size	Bond	Concentration
	Forme	mm	mm	mm	mm	Granulation	Liant	Concentration
	4B9/264	125	3	3,8	25	B 126	K833N	100

Sägeschärfen – Rückenschliff/Saw sharpening – back grinding/Affûtage des scies – Rectification de dos

Schliff des Spanwinkels – 18° bis 45°
Grinding of the rake angle – 18° to 45°
Rectification de l'angle de coupe - 18° à 45°

18° bis 45°
18° to 45°
18° à 45°

Schliff des Schrägwinkels – 0° bis 30°
Grinding of the inclined angle – 0° to 30°
Rectification de l'angle incliné – 0° à 30°

0° bis 30°
0° to 30°
0° à 30°

Tiefschleifen/Deep grinding/Rectification en plongée

Zustellung pro Hub Infeed per pass Profondeur de passe par course	Arbeitsgeschwindigkeit Cutting speed Vitesse de coupe	Vorschubgeschwindigkeit Feed rate Vitesse d'avance	Taktzeit (Vorschubzeit und Schleifzeit) Cycle time (infeed time and grinding time) Temps du cycle (temps d'avance et temps de rectification)
---	---	--	--

0,3 – 1,5 mm

18 – 23 m/s

50 – 200 mm/min

7 - 15 sec/Zahn
7 - 15 sec/tooth
7 - 15 sec/dent

Kühlmittel
Coolant
Refroidissement

Diamant
Diamond
Diamant

Bornitrid
Boron nitride
Niture de bore

Emulsion 1 : 30 – 50
Emulsion 1 : 30 – 50
Emulsion 1 : 30 – 50

Emulsion 1 : 20 – 40 mit EP-Zusatz
Emulsion 1 : 20 – 40 with EP additives
Emulsion 1 : 20 – 40 avec additifs EP

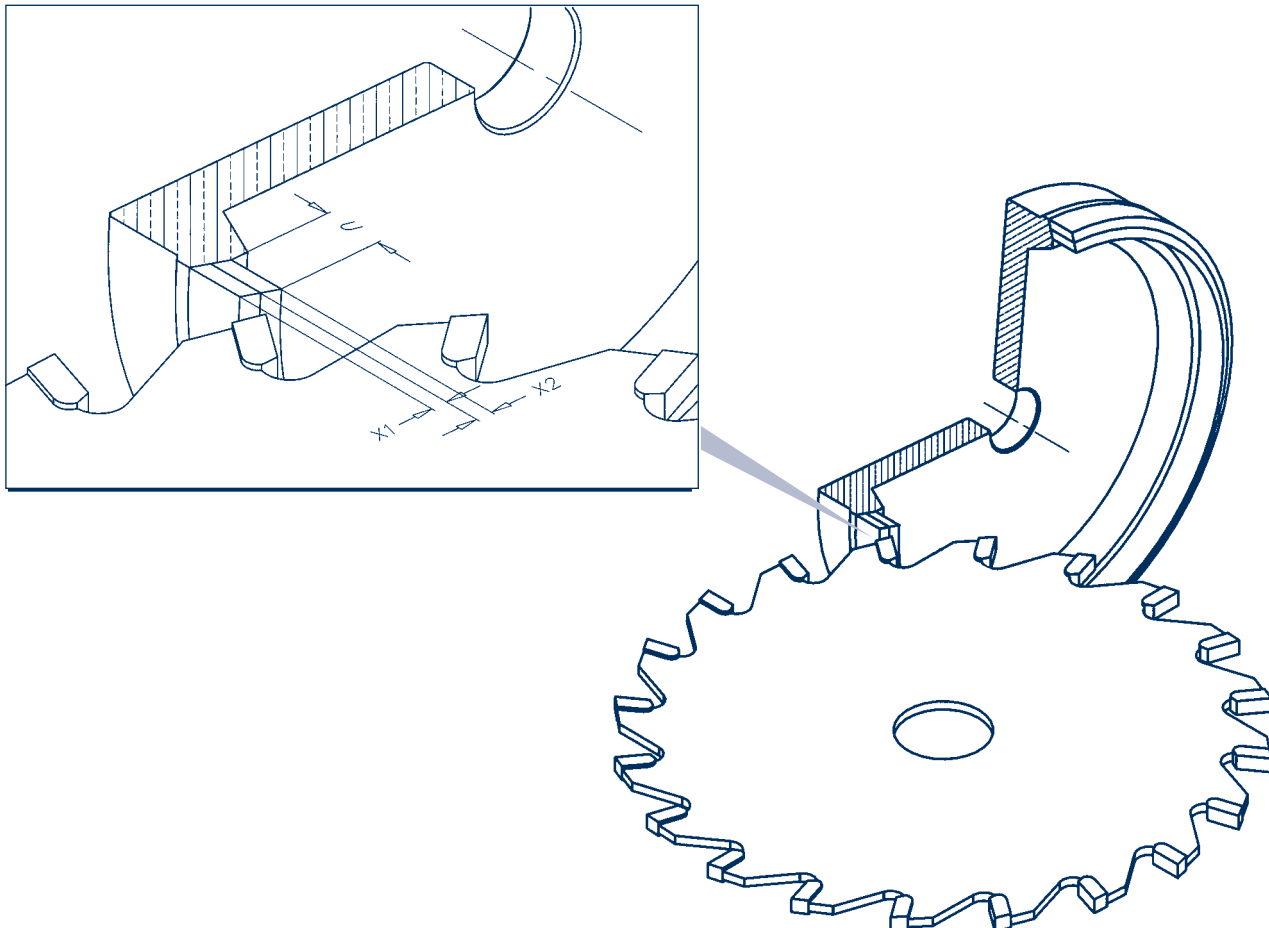

Rückenschliff im Tiefschleifverfahren von HM-bestückten Sägen Deep grinding the back of TC tipped saws Rectification en plongée du dos des lames de scies plaquette en métal dur

Diamant-Schleifscheiben/Diamond grinding wheels/Meules diamant

6A9/203

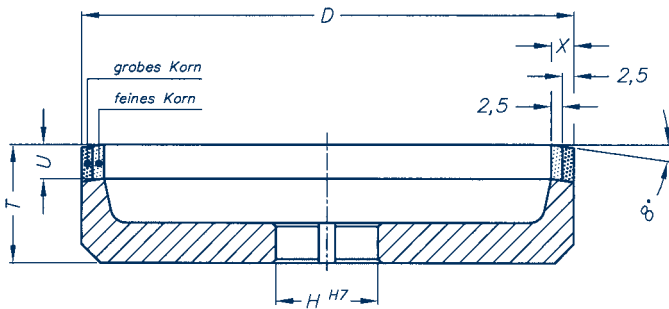

Normale Teilung – Aufmaß $\geq 0,2$ mm
 Normal pitch – allowance $\geq 0,2$ mm
 Pas normal – surépaisseur $\geq 0,2$ mm

D mm	X mm	U mm	T mm	H mm
100	5	6	20	nach Angabe as specified selon spécification
100	5	10	24	

Körnungsgröße Grit size Granulation	Bindung Bond Liant	Konzentration Concentration Concentration
D 126/D 46 (D 35)	K850R	100/75
D 126/D 46 (D 35)	K850R	100/75

Bestellbeispiel Order example Exemple de commande	Form	D	X	U	H	Körnungsgröße	Bindung	Konzentration
	Shape	mm	mm	mm	mm	Grit size	Bond	Concentration
	Forme	mm	mm	mm	mm	Granulation	Liant	Concentration
	6A9/203	100	5	6	25	D 126/D 46	K850R	100/75

4A2/211

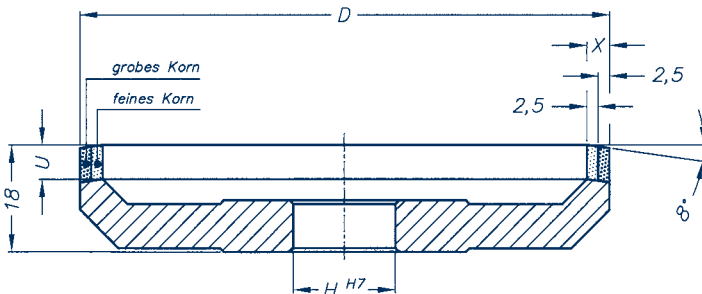

Normale Teilung – Aufmaß $\geq 0,3$ mm
 Normal pitch – allowance $\geq 0,3$ mm
 Pas normal – surépaisseur $\geq 0,3$ mm

D mm	X mm	U mm	H mm
125	5	6	nach Angabe as specified selon spécification
125	5	10	

Körnungsgröße Grit size Granulation	Bindung Bond Liant	Konzentration Concentration Concentration
D 126/D 46 (D 35)	K850R	100/75
D 126/D 46 (D 35)	K850R	100/75

Bestellbeispiel Order example Exemple de commande	Form	D	X	U	H	Körnungsgröße	Bindung	Konzentration
	Shape	mm	mm	mm	mm	Grit size	Bond	Concentration
	Forme	mm	mm	mm	mm	Granulation	Liant	Concentration
	4A2/211	125	5	6	32	D 126/D 46	K850R	100/75

Brust- und Rückenschliff im Tiefschleifverfahren auf „Vollmer-Dornhahn“-Maschine
Deep grinding of the face and the back on machine „Vollmer-Dornhahn“
Rectification en plongée de face et du dos sur machine „Vollmer-Dornhahn“

Diamant-Schleifscheiben/Diamond grinding wheels/Meules diamant

6A9/206

Maschinentyp: Alpha, Beta, Gamma,
 Machine type: Alpha, Beta, Gamma,
 Modèle de machine: Alpha, Beta, Gamma

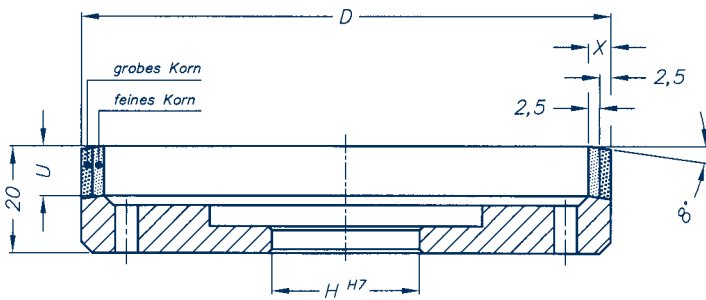

D mm	X mm	U mm	H mm
125	5	6	50,8
125	5	10	50,8

Körnungsgröße Grit size Granulation	Bindung Bond Liant	Konzentration Concentration Concentration
D 126/D 46 (D 35)	K850R	100/75
D 126/D 46 (D 35)	K850R	100/75

Bestellbeispiel Order example Exemple de commande	Form Shape Forme	D mm	X mm	U mm	H mm	Körnungsgröße Grit size Granulation	Bindung Bond Liant	Konzentration Concentration Concentration
6A9/206		125	5	10	50,8	D 126/D 46	K850R	100/75

6A9/207

Maschinentyp: Alpha, Beta, Gamma,
 Machine type: Alpha, Beta, Gamma,
 Modèle de machine: Alpha, Beta, Gamma

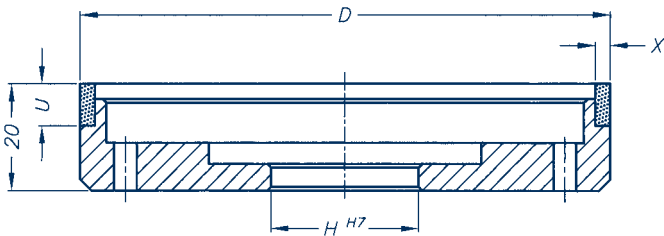

D mm	X mm	U mm	H mm
125	3	6	50,8

Körnungsgröße Grit size Granulation	Bindung Bond Liant	Konzentration Concentration Concentration
D 64	K850R	100

Bestellbeispiel Order example Exemple de commande	Form Shape Forme	D mm	X mm	U mm	H mm	Körnungsgröße Grit size Granulation	Bindung Bond Liant	Konzentration Concentration Concentration
6A9/207		125	3	6	50,8	D 64	K850R	100

4V9/208

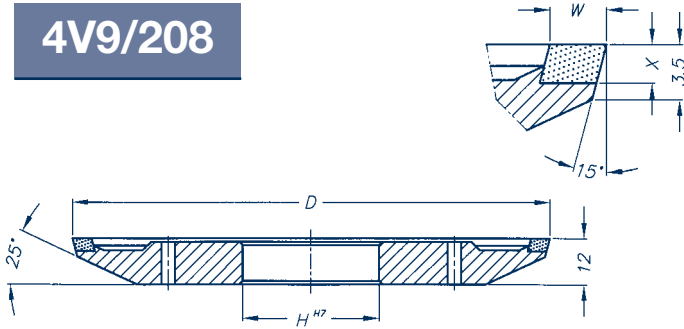

Maschinentyp: Alpha, Beta, Gamma,
Machine type: Alpha, Beta, Gamma,
Modèle de machine: Alpha, Beta, Gamma

D mm	W mm	X mm	H mm
175	5	3,3	50,8

4V9/209

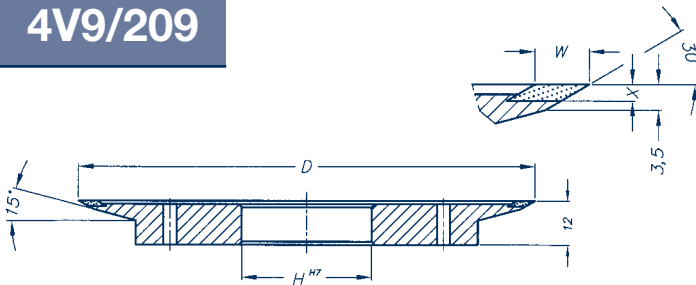

Maschinentyp: Alpha, Beta, Gamma,
Machine type: Alpha, Beta, Gamma,
Modèle de machine: Alpha, Beta, Gamma

D mm	W mm	X mm	H mm
175	4	2	50,8

4V9/210

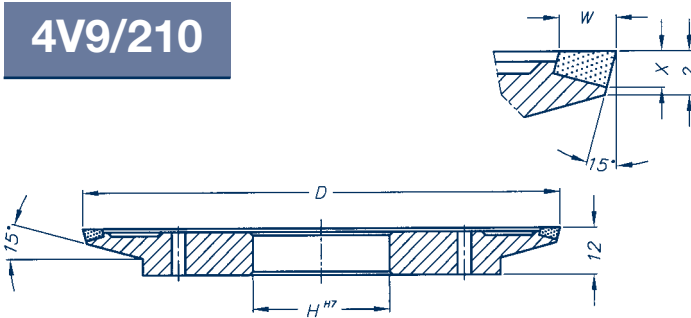

Maschinentyp: Alpha, Beta, Gamma,
Machine type: Alpha, Beta, Gamma,
Modèle de machine: Alpha, Beta, Gamma

D mm	W mm	X mm	H mm
175	3	1,8	50,8

Körnungsgröße Grit size Granulation	Bindung Bond Liant	Konzentration Concentration Concentration
D 76	K850R	125

Bestellbeispiel Order example Exemple de commande	Form	D	W	X	H	Körnungsgröße	Bindung	Konzentration
	Shape	mm	mm	mm	mm	Grit size	Bond	Concentration
Forme	mm	mm	mm	mm	mm	Granulation	Liant	Concentration
4V9/208	175	5	3,3	50,8	D 76	K850R	125	
4V9/209	175	4	2	50,8	D 76	K850R	125	
4V9/210	175	3	1,8	50,8	D 76	K850R	125	

14B1/105

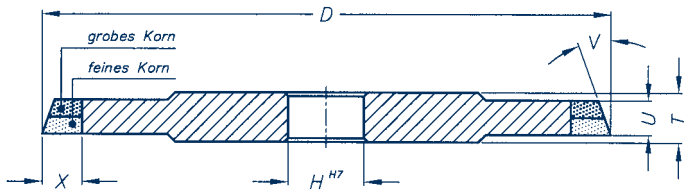

D mm	U mm	X mm	T mm	H mm
127	5	10	8	nach Angabe as specified selon spécification

Körnungsgröße Grit size Granulation	Bindung Bond Liant	Konzentration Concentration Concentration
D 126/D 46	K850R	100/75

Bestellbeispiel Order example Exemple de commande

Form Shape Forme	D mm	U mm	X mm	H mm	Körnungsgröße Grit size Granulation	Bindung Bond Liant	Konzentration Concentration Concentration
14B1/105	127	5	10	25	D 126/D 46	K850R	100/75

14A1/106

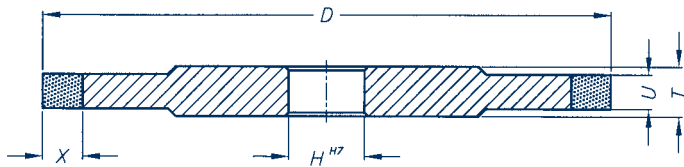

D mm	U mm	X mm	T mm	H mm
150	5	10	8	nach Angabe as specified selon spécification

Körnungsgröße Grit size Granulation	Bindung Bond Liant	Konzentration Concentration Concentration
D 64	K850R	100

Bestellbeispiel Order example Exemple de commande

Form Shape Forme	D mm	U mm	X mm	H mm	Körnungsgröße Grit size Granulation	Bindung Bond Liant	Konzentration Concentration Concentration
14A1/106	150	5	10	25	D 64	K850R	100

14M1/107

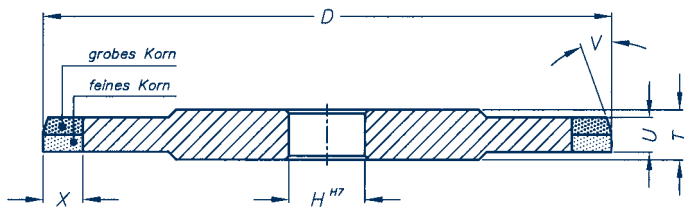

D mm	U mm	X mm	T mm	H mm
150	5	10	8	nach Angabe as specified selon spécification

Körnungsgröße Grit size Granulation	Bindung Bond Liant	Konzentration Concentration Concentration
D 126/D 46	K850R	100/75

Bestellbeispiel Order example Exemple de commande

Form Shape Forme	D mm	U mm	X mm	H mm	Körnungsgröße Grit size Granulation	Bindung Bond Liant	Konzentration Concentration Concentration
14M1/107	150	5	10	25	D 126/D 46	K850R	100/75

Rückenschliff im Tiefschleifverfahren von Sägen und Fräsern aus HSS Deep grinding the back of high speed steel of saws and milling cutters Rectification en plongée du dos des lames de scies et fraise en acier à coupe rapide

Bornitrid-Schleifscheiben/Boron nitride grinding wheels/Meules nitrure de bore

11V9/271

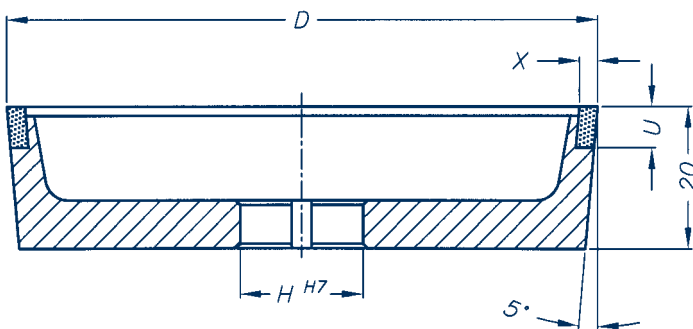

Auch Schleifen der Eckfasen an den Vorschneidezähnen der HSS-Sägen
 Also grinding of the corner chamfers on the roughing teeth of high speed steel saws
 Aussi la rectification des chanfreins d'angle de la dent degrossisseuse de lames de scies en acier à coupe rapide

D mm	X mm	U mm	H mm
100	3	6	nach Angabe as specified selon spécification

Körnungsgröße Grit size Granulation	Bindung Bond Liant	Konzentration Concentration Concentration
B 126 B 126	K833N K833N	75 75

Bestellbeispiel Order example Exemple de commande	Form Shape Forme	D mm	X mm	U mm	H mm	Körnungsgröße Grit size Granulation	Bindung Bond Liant	Konzentration Concentration Concentration
	11V9/271	100	3	6	25	B 126	K833N	75

11B9/272

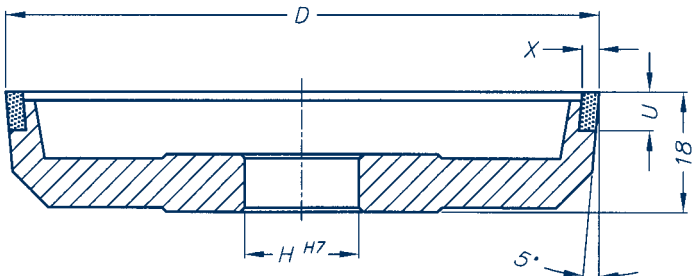

Enge Teilung – Aufmaß >0,3 mm
 Narrow pitch – allowance >0,3 mm
 Pas étroit – surépaisseur >0,3 mm

D mm	X mm	U mm	H mm
125	3	6,5	nach Angabe as specified selon spécification

Körnungsgröße Grit size Granulation	Bindung Bond Liant	Konzentration Concentration Concentration
B 126 B 126	K833N K833N	75 100

Bestellbeispiel Order example Exemple de commande	Form Shape Forme	D mm	X mm	U mm	H mm	Körnungsgröße Grit size Granulation	Bindung Bond Liant	Konzentration Concentration Concentration
	11B9/272	125	3	6,5	32	B 126	K833N	100

Sägeschärfen – Zahnflankenschliff

Saw sharpening – profile grinding of gear teeth

Affûtage des scies – Affûtage du profil des dents

Pendelschleifen/Oscillation grinding/Rectification oscillante		
Zustellung	0,06 – 0,1 mm 0,2 – 0,5 mm	Reparaturschliff Produktionsschliff
Infeed	0,06 – 0,1 mm 0,2 – 0,5 mm	Resharpening Production grinding
Profondeur de passe	0,06 – 0,1 mm 0,2 – 0,5 mm	Affûtage de réparation Affûtage de production
Zustellung pro Doppelhub Infeed per double pass Profondeur de passe par cours double	0,02 – 0,04 mm 0,02 – 0,04 mm 0,02 – 0,04 mm	Reparatur-/Produktionsschliff Resharpening /production grinding Affûtage de réparation/production
Arbeitsgeschwindigkeit Cutting speed Vitesse de coupe	17 – 18 m/s	
Hubzahl Number of passe Nombre de course	60 – 120 per min	
Kühlmittel Coolant Refroidissement	Emulsion 1 : 30 – 50 Emulsion 1 : 30 – 50 Emulsion 1 : 30 – 50	
Tiefschleifen/Deep grinding/Rectification en plongée		
Zustellung	0,06 – 0,1 mm 0,2 – 0,5 mm	Reparaturschliff Produktionsschliff
Infeed	0,06 – 0,1 mm 0,2 – 0,5 mm	Resharpening Production grinding
Profondeur de passe	0,06 – 0,1 mm 0,2 – 0,5 mm	Affûtage de réparation Affûtage de production
Zustellung pro Hub Infeed per pass Profondeur de passe par cours	0,06 – 0,1 mm 0,2 – 0,5 mm	Reparaturschliff / Resharpening Affûtage de réparation Produktionsschliff / production grinding Affûtage de réparation/production
Arbeitsgeschwindigkeit Cutting speed Vitesse de coupe	17 – 18 m/s	
Vorschubgeschwindigkeit Feed rate Vitesse d'avance	3 – 5 mm/s	
Taktzeit (Vorschubzeit und Schleifzeit) Cycle time (infeed time and grinding time) Temps du cycle (temps d'avance et temps de rectification)	12 – 15 sec/Zahn 12 – 15 sec/tooth 12 – 15 sec/dent	
Kühlmittel Coolant Refroidissement	Emulsion 1 : 30 – 50 Emulsion 1 : 30 – 50 Emulsion 1 : 30 – 50	

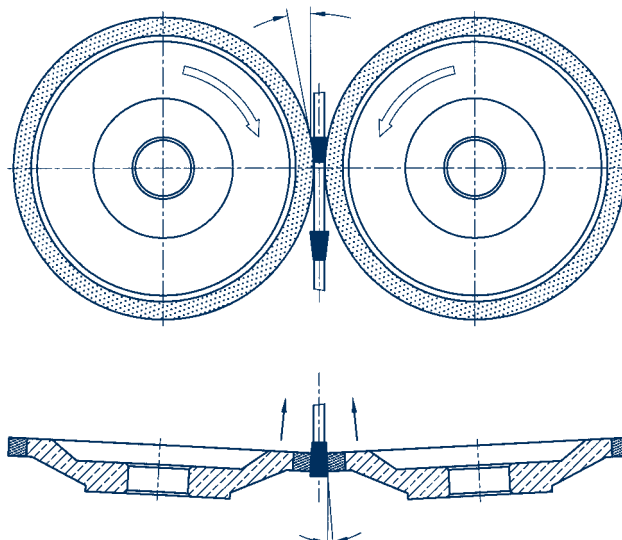

Zahnflankenschliff im Pendelschleifverfahren von HM-bestückten Sägen

Oscillation profile grinding of gear teeth of TC tipped saws

Rectification oscillante des profils des dents des lames de scies plaquette en métal dur

Diamant-Schleifscheiben/Diamond grinding wheels/Meules diamant

12A1/231

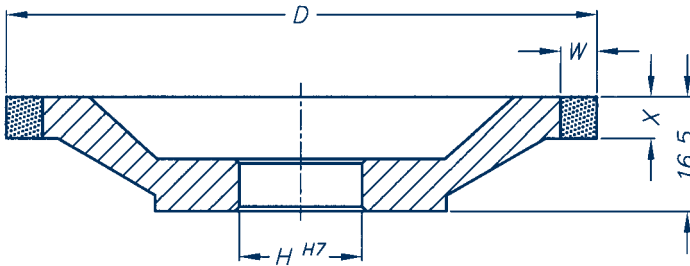

Paarweiser Einsatz/Use in pair/Emploi pairé

D mm	X mm	W mm	H mm
100	4	4	nach Angabe as specified selon spécification

Körnungsgröße Grit size Granulation	Bindung Bond Liant	Konzentration Concentration Concentration
D 126	K850R	50
D 126	K850R	75
D 126	K850R	100

Bestellbeispiel Order example Exemple de commande	Form Shape Forme	D mm	X mm	W mm	H mm	Körnungsgröße Grit size Granulation	Bindung Bond Liant	Konzentration Concentration Concentration
	12A1/231	100	4	4	20	D 126	K850R	75

Zahnflankenschliff im Tiefschleifverfahren von HM-bestückten Sägen

Deep grinding of gear teeth of TC tipped saws

Rectification en plongée des profils des dents des lames de scies plaquette en metal dur

Diamant-Schleifscheiben/Diamond grinding wheels/Meules diamant

4B9/233

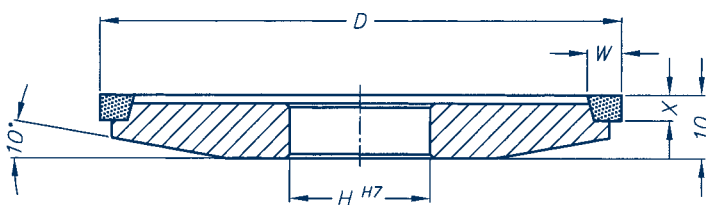

Paarweiser Einsatz/Use in pair/Emploi pairé

D mm	X mm	W mm	H mm
80	4	5	nach Angabe as specified selon spécification
100	4	5	

Körnungsgröße Grit size Granulation	Bindung Bond Liant	Konzentration Concentration Concentration
D 91	K850R	50
D 126	K850R	50
D 126	K850R	75

Bestellbeispiel Order example Exemple de commande	Form Shape Forme	D mm	X mm	W mm	H mm	Körnungsgröße Grit size Granulation	Bindung Bond Liant	Konzentration Concentration Concentration
	4B9/233	100	4	5	32	D 126	K850R	75

Sonderwerkzeuge/Special tools/Outils spéciaux

Diamant-Profilschleifscheibe für Dübelbohrer
Diamond profile grinding wheel for pin drills
Meule diamant profilée pour forets à plaquettes

14E1/1

D mm	U mm	B mm	X mm	H mm	Bohrer ø mm Drill ø mm Foret ø mm
75	4,5	0,9	6	nach Angabe as specified selon spécification	4
75	4,5	1,9	6		6
75	5,0	2,8	6		8
75	6,0	3,7	6		10

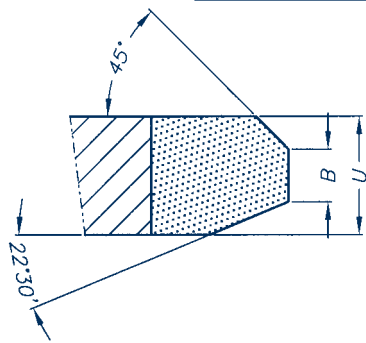

Körnunggröße Grit size Granulation	Bindung Bond Liant	Konzentration Concentration Concentration
D 64	K200R	50
D 64	K200R	75

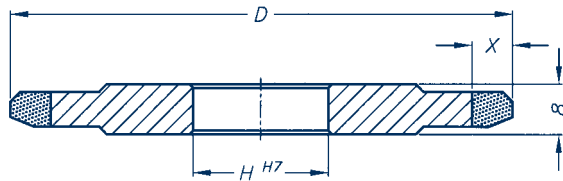

Bestellbeispiel Order example Exemple de commande	Form Shape Forme	D mm	U mm	B mm	X mm	H mm	Körnunggröße Grit size Granulation	Bindung Bond Liant	Konzentration Concentration Concentration
	14E1/1	75	5	2,8	6	20	D 64	K200R	50

14F1

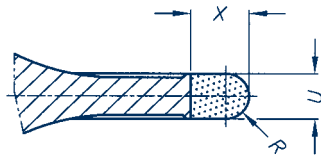

D mm	U mm	X mm	R mm	H mm
200	2	7	1	nach Angabe as specified selon spécification
200	4	7	2	

Körnunggröße Grit size Granulation	Bindung Bond Liant	Konzentration Concentration Concentration
D 64	K200R	50
D 64	K200R	75

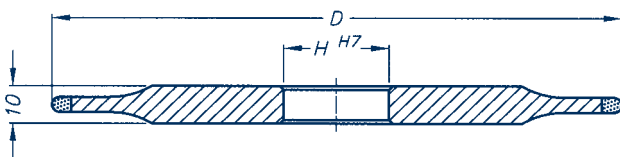

Bestellbeispiel Order example Exemple de commande	Form Shape Forme	D mm	U mm	X mm	R mm	H mm	Körnunggröße Grit size Granulation	Bindung Bond Liant	Konzentration Concentration Concentration
	14F1	200	2	7	1	20	D 64	K200R	50

Lieferprogramm

Schleifen

- Schleifscheiben
- Innenschleifwerkzeuge
- Schleifzylinder
- Sonderwerkzeuge nach Zeichnung

Trennen

- Trennscheiben, geschlossener Schneidrand
- Trennscheiben, segmentierter Schneidrand
- Bandsägen
- Sägedrähte

Abrichten

- Einzelabrichter
- Vielkornabrichter
- Mehrsteinabrichter
- Handabrichter
- Profilabrichter
- Abrichtplatten
- Abrichträdchen
- Abrichtblöcke
- Abrichtrollen
- Schärfsteine

Feilen

- Nadelfeilen
- Werkstattfeilen
- Riffelfeilen
- Maschinenfeilen

Bohren

- Hohlbohrer
- Doppelhohlbohrer
- Sacklochbohrer
- Senker

Polieren

- Polierpasten
- Polierpulver
- Polierfolien

Product range

Grinding

- grinding wheels
- internal grinding tools
- grinding cylinders
- special tools according drawings

Cutting

- saw blades with continuous rim
- saw blades with segmented rim
- band saws
- saw wires

Dressing

- single point diamond dresser
- diamond impregnated dresser
- multipoint diamond dresser
- hand-held diamond dresser
- polished diamond profilers
- dressing plates
- roller dressers
- dressing blocks
- dressing rolls
- dressing sticks

Filing

- needle shaped files
- workshop files
- fluted files
- machine files

Drilling

- core drills
- double core drills
- blind hole drills
- countersinks and counterbores

Polishing

- polishing pastes
- polishing powder
- polishing foils

Programme de livraison

Rectification et affûtage

- meules
- outils pour la rectification intérieure
- cylindres
- outils spéciaux d'après dessin

Tronçonnage

- disques à tronçonner à jante continue
- disques à tronçonner à jante segmentée
- scies à ruban
- lames de scie

Dressage

- diamant de dressage à pointe unique
- dresseur à concrétion diamantée
- dresseurs diamant à pointes multiples
- dresseurs diamant manuel
- diamant profilés
- plaques de dressage diamant
- roulettes de dressage diamant
- blocs de dressage
- dresseurs rotatifs diamant
- pierre d'avivage

Limage

- limes en aiguille
- limes d'atelier
- limes rifloirs
- limes pour machines

Forage

- forets couronne
- forets couronne double
- forets à trous borgnes
- outils à chanfreiner et à lamer

Polissage

- pâtes de polissage
- poudre de polissage
- film de polissage

EFFGEN

Diamant- und Bornitridwerkzeuge

EFFGEN

Diamant- und Bornitridwerkzeuge

Günter Effgen GmbH
D-55756 Herrstein · Postfach 80 · Am Teich 3-5
Tel. +49 (0) 67 85/18-0
Fax +49 (0) 67 85/18 58 + 7547
e-Mail: info@effgen.com
Internet: <http://www.effgen.com>